

Alliant Engineering Inc Minneapolis, MN 55415

TH-55 at Co.Rd. 101, East Jct
Ref.Pt.: 177.578
Alliant Engineering Inc
TURN MOVEMENT COUNT

File Name : 34_TH 55 at CR 101 E Jct_012711
Site Code : 00000034
Start Date : 1/27/2011
Page No : 1

Groups Printed- Unshifted - Bank 1

Start Time	Peony Lane N Southbound				TH-55 Westbound				Co.Rd.101 Northbound				TH-55 Eastbound				Int. Total
	Left	Thru	Rght	Peds	Left	Thru	Rght	Peds	Left	Thru	Rght	Peds	Left	Thru	Rght	Peds	
06:00	10	14	2	0	3	46	2	0	4	5	4	0	2	245	14	0	351
06:15	21	3	1	0	6	57	13	0	6	11	4	0	1	328	21	0	472
06:30	18	7	0	0	9	101	23	0	11	22	13	0	1	430	25	0	660
06:45	34	23	0	0	8	114	52	0	16	115	6	0	3	425	44	0	840
Total	83	47	3	0	26	318	90	0	37	153	27	0	7	1428	104	0	2323
07:00	67	65	0	0	11	74	109	0	24	140	12	0	3	476	42	0	1023
07:15	89	62	2	0	12	89	22	0	15	26	10	0	2	570	80	0	979
07:30	68	72	1	0	15	89	15	0	11	34	12	0	1	553	82	0	953
07:45	27	67	1	0	9	128	12	0	11	55	14	0	2	490	98	0	914
Total	251	266	4	0	47	380	158	0	61	255	48	0	8	2089	302	0	3869
08:00	36	45	0	0	11	78	9	0	7	47	9	0	5	406	51	0	704
08:15	32	49	2	0	7	104	14	0	15	24	15	0	5	397	33	0	697
08:30	29	21	4	0	2	93	14	2	19	25	16	0	1	288	39	0	553
08:45	28	24	0	0	10	103	13	0	18	19	14	0	8	285	45	0	567
Total	125	139	6	0	30	378	50	2	59	115	54	0	19	1376	168	0	2521
09:00	36	26	5	0	11	79	7	0	23	15	16	0	8	220	24	0	470
09:15	27	22	1	0	5	84	9	0	14	17	7	0	1	207	21	0	415
*** BREAK ***																	
Total	63	48	6	0	16	163	16	0	37	32	23	0	9	427	45	0	885
*** BREAK ***																	
10:30	15	18	6	0	8	113	16	0	21	15	15	0	3	130	23	0	383
10:45	28	7	1	0	9	108	10	0	15	7	14	0	6	135	16	0	356
Total	43	25	7	0	17	221	26	0	36	22	29	0	9	265	39	0	739
11:00	15	9	2	0	10	126	19	0	24	8	16	0	1	138	14	0	382
11:15	20	10	2	0	7	98	21	0	9	12	16	0	6	176	20	0	397
11:30	18	16	4	0	13	131	20	0	20	18	15	0	5	148	11	0	419
11:45	19	16	2	0	11	134	27	0	25	24	28	0	5	136	11	0	438
Total	72	51	10	0	41	489	87	0	78	62	75	0	17	598	56	0	1636
12:00	18	16	3	0	12	145	19	0	21	17	16	0	11	167	20	0	465
12:15	20	16	2	0	12	153	17	0	35	25	15	0	7	118	23	0	443
12:30	23	16	4	0	22	183	19	0	17	21	13	0	11	154	20	0	503
12:45	28	28	4	0	14	158	23	0	17	24	9	0	7	140	19	0	471
Total	89	76	13	0	60	639	78	0	90	87	53	0	36	579	82	0	1882
13:00	30	40	6	0	16	182	16	0	21	12	16	0	7	141	19	0	506
13:15	20	15	10	0	14	155	23	0	24	16	19	0	5	139	19	0	459
*** BREAK ***																	
Total	50	55	16	0	30	337	39	0	45	28	35	0	12	280	38	0	965
*** BREAK ***																	
14:30	133	123	4	0	15	244	18	0	30	46	34	0	3	118	13	0	781
14:45	54	49	3	0	17	220	20	0	51	40	20	0	1	114	20	0	609
Total	187	172	7	0	32	464	38	0	81	86	54	0	4	232	33	0	1390
15:00	39	43	4	0	5	287	17	1	36	36	19	0	6	134	22	0	649
15:15	41	38	3	0	15	318	31	0	38	55	11	0	9	183	24	0	766
15:30	43	50	4	0	11	367	34	0	54	38	17	0	6	168	11	0	803
15:45	39	35	5	0	13	385	23	0	55	51	12	0	6	113	22	0	759
Total	162	166	16	0	44	1357	105	1	183	180	59	0	27	598	79	0	2977

Alliant Engineering Inc Minneapolis, MN 55415

TH-55 at Co.Rd. 101, East Jct
Ref.Pt.: 177.578
Alliant Engineering Inc
TURN MOVEMENT COUNT

File Name : 34_TH 55 at CR 101 E Jct_012711
Site Code : 00000034
Start Date : 1/27/2011
Page No : 2

Groups Printed- Unshifted - Bank 1

Start Time	Peony Lane N Southbound				TH-55 Westbound				Co.Rd.101 Northbound				TH-55 Eastbound				Int. Total
	Left	Thru	Rght	Peds	Left	Thru	Rght	Peds	Left	Thru	Rght	Peds	Left	Thru	Rght	Peds	
16:00	44	27	2	0	24	418	31	0	79	60	19	0	3	136	10	0	853
16:15	34	41	4	0	10	463	33	0	70	46	12	0	5	166	22	0	906
16:30	38	31	4	0	11	466	35	0	80	65	18	0	9	173	19	0	949
16:45	34	45	5	0	22	485	44	0	78	73	22	0	11	158	21	0	998
Total	150	144	15	0	67	1832	143	0	307	244	71	0	28	633	72	0	3706
17:00	27	38	5	0	17	439	43	0	85	61	15	0	5	198	21	0	954
17:15	57	48	4	0	22	522	47	0	116	64	12	0	11	178	24	0	1105
17:30	48	48	6	0	18	391	42	0	103	48	18	0	5	171	17	0	915
17:45	36	18	1	0	19	337	18	0	79	46	16	0	8	122	15	0	715
Total	168	152	16	0	76	1689	150	0	383	219	61	0	29	669	77	0	3689
Grand Total	1443	1341	119	0	486	8267	980	3	1397	1483	589	0	205	9174	1095	0	26582
Apprch %	49.7	46.2	4.1	0	5	84.9	10.1	0	40.3	42.8	17	0	2	87.6	10.5	0	
Total %	5.4	5	0.4	0	1.8	31.1	3.7	0	5.3	5.6	2.2	0	0.8	34.5	4.1	0	
Unshifted	1371	1285	115	0	460	8065	928	3	1358	1431	569	0	195	8935	1072	0	25787
% Unshifted	95	95.8	96.6	0	94.7	97.6	94.7	100	97.2	96.5	96.6	0	95.1	97.4	97.9	0	97
Bank 1	72	56	4	0	26	202	52	0	39	52	20	0	10	239	23	0	795
% Bank 1	5	4.2	3.4	0	5.3	2.4	5.3	0	2.8	3.5	3.4	0	4.9	2.6	2.1	0	3

Alliant Engineering Inc Minneapolis, MN 55415

TH-55 at Co.Rd. 101, East Jct
Ref.Pt.: 177.578
Alliant Engineering Inc
TURN MOVEMENT COUNT

File Name : 34_TH 55 at CR 101 E Jct_012711
Site Code : 00000034
Start Date : 1/27/2011
Page No : 3

Start Time	Peony Lane N Southbound					TH-55 Westbound					Co.Rd.101 Northbound					TH-55 Eastbound					Int. Total
	Left	Thru	Rght	Peds	App. Total	Left	Thru	Rght	Peds	App. Total	Left	Thru	Rght	Peds	App. Total	Left	Thru	Rght	Peds	App. Total	
Peak Hour Analysis From 06:00 to 09:15 - Peak 1 of 1																					
Peak Hour for Entire Intersection Begins at 07:00																					
07:00	67	65	0	0	132	11	74	109	0	194	24	140	12	0	176	3	476	42	0	521	1023
07:15	89	62	2	0	153	12	89	22	0	123	15	26	10	0	51	2	570	80	0	652	979
07:30	68	72	1	0	141	15	89	15	0	119	11	34	12	0	57	1	553	82	0	636	953
07:45	27	67	1	0	95	9	128	12	0	149	11	55	14	0	80	2	490	98	0	590	914
Total Volume	251	266	4	0	521	47	380	158	0	585	61	255	48	0	364	8	2089	302	0	2399	3869
% App. Total	48.2	51.1	0.8	0		8	65	27	0		16.8	70.1	13.2	0		0.3	87.1	12.6	0		
PHF	.705	.924	.500	.000	.851	.783	.742	.362	.000	.754	.635	.455	.857	.000	.517	.667	.916	.770	.000	.920	.946

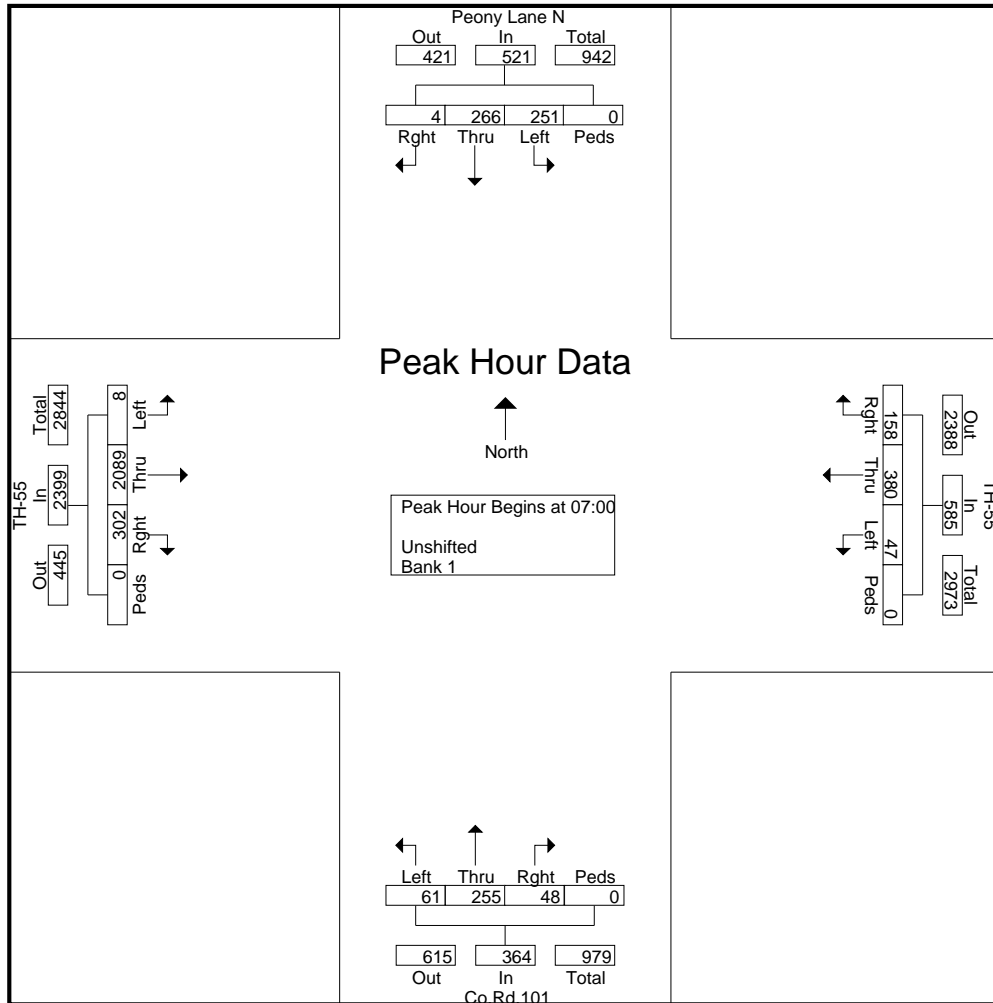

Alliant Engineering Inc Minneapolis, MN 55415

TH-55 at Co.Rd. 101, East Jct
Ref.Pt.: 177.578
Alliant Engineering Inc
TURN MOVEMENT COUNT

File Name : 34_TH 55 at CR 101 E Jct_012711
Site Code : 00000034
Start Date : 1/27/2011
Page No : 4

Start Time	Peony Lane N Southbound					TH-55 Westbound					Co.Rd.101 Northbound					TH-55 Eastbound					Int. Total
	Left	Thru	Rght	Peds	App. Total	Left	Thru	Rght	Peds	App. Total	Left	Thru	Rght	Peds	App. Total	Left	Thru	Rght	Peds	App. Total	
Peak Hour Analysis From 14:30 to 17:45 - Peak 1 of 1																					
Peak Hour for Entire Intersection Begins at 16:30																					
16:30	38	31	4	0	73	11	466	35	0	512	80	65	18	0	163	9	173	19	0	201	949
16:45	34	45	5	0	84	22	485	44	0	551	78	73	22	0	173	11	158	21	0	190	998
17:00	27	38	5	0	70	17	439	43	0	499	85	61	15	0	161	5	198	21	0	224	954
17:15	57	48	4	0	109	22	522	47	0	591	116	64	12	0	192	11	178	24	0	213	1105
Total Volume	156	162	18	0	336	72	1912	169	0	2153	359	263	67	0	689	36	707	85	0	828	4006
% App. Total	46.4	48.2	5.4	0		3.3	88.8	7.8	0		52.1	38.2	9.7	0		4.3	85.4	10.3	0		
PHF	.684	.844	.900	.000	.771	.818	.916	.899	.000	.911	.774	.901	.761	.000	.897	.818	.893	.885	.000	.924	.906

