



MINNESOTA DEPT OF TRANSPORTATION

TRAFFIC DATA COLLECTION - METRO

Counted By: Joanne & Aimee
 Day of the Week: Tuesday
 Location: TH 55 & CR101/Sioux
 Project #: 5764

File Name : TH 55 @ CR 101-SIOUX 2006
 Site Code : 07250312
 Start Date : 7/25/2006
 Page No : 1

Groups Printed- Unshifted

| Start Time | CR101 Southbound | | | | | TH55 Westbound | | | | | Sioux Northbound | | | | | TH55 Eastbound | | | | | Int. Total |
|--------------------|------------------|------------|-------------|----------|-------------|----------------|-------------|-------------|----------|-------------|------------------|------------|-------------|------------|------------|----------------|-------------|------------|----------|-------------|--------------|
| | Left | Thru | Right | Peds | App. Total | Left | Thru | Right | Peds | App. Total | Left | Thru | Right | Peds | App. Total | Left | Thru | Right | Peds | App. Total | |
| 06:00 | 20 | 4 | 2 | 0 | 26 | 0 | 0 | 0 | 0 | 0 | 0 | 0 | 0 | 1 | 1 | 9 | 334 | 4 | 0 | 347 | 374 |
| 06:15 | 66 | 3 | 10 | 0 | 79 | 1 | 66 | 9 | 0 | 76 | 11 | 17 | 7 | 0 | 35 | 14 | 478 | 25 | 0 | 517 | 707 |
| 06:30 | 99 | 6 | 17 | 0 | 122 | 4 | 112 | 41 | 0 | 157 | 7 | 10 | 12 | 0 | 29 | 14 | 476 | 14 | 0 | 504 | 812 |
| 06:45 | 144 | 21 | 13 | 0 | 178 | 5 | 124 | 41 | 0 | 170 | 5 | 9 | 11 | 0 | 25 | 28 | 439 | 18 | 0 | 485 | 858 |
| Total | 329 | 34 | 42 | 0 | 405 | 10 | 302 | 91 | 0 | 403 | 23 | 36 | 30 | 1 | 90 | 65 | 1727 | 61 | 0 | 1853 | 2751 |
| 07:00 | 161 | 6 | 21 | 0 | 188 | 6 | 124 | 25 | 0 | 155 | 11 | 10 | 5 | 0 | 26 | 14 | 456 | 12 | 0 | 482 | 851 |
| 07:15 | 185 | 14 | 21 | 0 | 220 | 9 | 105 | 20 | 0 | 134 | 10 | 0 | 3 | 0 | 13 | 13 | 444 | 18 | 0 | 475 | 842 |
| 07:30 | 198 | 16 | 17 | 0 | 231 | 7 | 124 | 22 | 0 | 153 | 7 | 3 | 4 | 0 | 14 | 21 | 456 | 12 | 0 | 489 | 887 |
| 07:45 | 191 | 22 | 22 | 0 | 235 | 11 | 102 | 23 | 0 | 136 | 25 | 15 | 13 | 0 | 53 | 12 | 387 | 23 | 0 | 422 | 846 |
| Total | 735 | 58 | 81 | 0 | 874 | 33 | 455 | 90 | 0 | 578 | 53 | 28 | 25 | 0 | 106 | 60 | 1743 | 65 | 0 | 1868 | 3426 |
| 08:00 | 104 | 13 | 12 | 0 | 129 | 14 | 108 | 24 | 0 | 146 | 11 | 10 | 2 | 0 | 23 | 27 | 375 | 24 | 0 | 426 | 724 |
| 08:15 | 106 | 4 | 6 | 0 | 116 | 2 | 101 | 23 | 0 | 126 | 14 | 7 | 7 | 0 | 28 | 16 | 344 | 18 | 0 | 378 | 648 |
| 08:30 | 98 | 5 | 13 | 0 | 116 | 12 | 106 | 48 | 0 | 166 | 14 | 12 | 13 | 0 | 39 | 15 | 280 | 13 | 0 | 308 | 629 |
| 08:45 | 96 | 13 | 8 | 0 | 117 | 7 | 77 | 24 | 0 | 108 | 10 | 6 | 2 | 0 | 18 | 11 | 257 | 21 | 0 | 289 | 532 |
| Total | 404 | 35 | 39 | 0 | 478 | 35 | 392 | 119 | 0 | 546 | 49 | 35 | 24 | 0 | 108 | 69 | 1256 | 76 | 0 | 1401 | 2533 |
| 11:00 | 66 | 13 | 11 | 0 | 90 | 10 | 111 | 51 | 0 | 172 | 6 | 4 | 2 | 2 | 14 | 8 | 154 | 11 | 0 | 173 | 449 |
| 11:15 | 42 | 5 | 10 | 0 | 57 | 5 | 160 | 45 | 0 | 210 | 20 | 9 | 4 | 4 | 37 | 12 | 160 | 17 | 0 | 189 | 493 |
| 11:30 | 43 | 5 | 15 | 0 | 63 | 4 | 141 | 38 | 0 | 183 | 7 | 15 | 13 | 2 | 37 | 22 | 162 | 13 | 0 | 197 | 480 |
| 11:45 | 44 | 8 | 15 | 0 | 67 | 5 | 153 | 60 | 0 | 218 | 12 | 7 | 8 | 2 | 29 | 9 | 176 | 18 | 0 | 203 | 517 |
| Total | 195 | 31 | 51 | 0 | 277 | 24 | 565 | 194 | 0 | 783 | 45 | 35 | 27 | 10 | 117 | 51 | 652 | 59 | 0 | 762 | 1939 |
| 12:00 | 47 | 10 | 17 | 0 | 74 | 6 | 130 | 59 | 0 | 195 | 23 | 7 | 8 | 1 | 39 | 20 | 173 | 18 | 0 | 211 | 519 |
| 12:15 | 32 | 7 | 13 | 0 | 52 | 6 | 127 | 53 | 0 | 186 | 10 | 12 | 5 | 2 | 29 | 15 | 202 | 13 | 0 | 230 | 497 |
| 12:30 | 66 | 6 | 14 | 0 | 86 | 16 | 152 | 35 | 0 | 203 | 15 | 10 | 2 | 1 | 28 | 24 | 158 | 24 | 0 | 206 | 523 |
| 12:45 | 34 | 5 | 20 | 0 | 59 | 6 | 155 | 51 | 0 | 212 | 10 | 15 | 3 | 3 | 31 | 18 | 146 | 15 | 0 | 179 | 481 |
| Total | 179 | 28 | 64 | 0 | 271 | 34 | 564 | 198 | 0 | 796 | 58 | 44 | 18 | 7 | 127 | 77 | 679 | 70 | 0 | 826 | 2020 |
| 15:00 | 41 | 12 | 16 | 0 | 69 | 0 | 248 | 44 | 0 | 292 | 12 | 8 | 4 | 1 | 25 | 6 | 148 | 12 | 0 | 166 | 552 |
| 15:15 | 41 | 7 | 23 | 0 | 71 | 0 | 278 | 60 | 0 | 338 | 9 | 15 | 3 | 0 | 27 | 13 | 125 | 12 | 0 | 150 | 586 |
| 15:30 | 39 | 6 | 17 | 0 | 62 | 3 | 299 | 73 | 1 | 376 | 15 | 13 | 5 | 5 | 38 | 15 | 194 | 16 | 0 | 225 | 701 |
| 15:45 | 48 | 7 | 20 | 0 | 75 | 3 | 290 | 78 | 0 | 371 | 6 | 20 | 2 | 1 | 29 | 7 | 178 | 15 | 0 | 200 | 675 |
| Total | 169 | 32 | 76 | 0 | 277 | 6 | 1115 | 255 | 1 | 1377 | 42 | 56 | 14 | 7 | 119 | 41 | 645 | 55 | 0 | 741 | 2514 |
| 16:00 | 50 | 9 | 9 | 0 | 68 | 1 | 401 | 98 | 0 | 500 | 17 | 15 | 7 | 1 | 40 | 22 | 214 | 14 | 0 | 250 | 858 |
| 16:15 | 37 | 15 | 15 | 0 | 67 | 1 | 364 | 135 | 0 | 500 | 18 | 10 | 10 | 0 | 38 | 9 | 153 | 13 | 0 | 175 | 780 |
| 16:30 | 49 | 3 | 16 | 0 | 68 | 2 | 332 | 145 | 0 | 479 | 6 | 16 | 1 | 0 | 23 | 24 | 184 | 11 | 0 | 219 | 789 |
| 16:45 | 50 | 5 | 7 | 0 | 62 | 5 | 375 | 117 | 0 | 497 | 16 | 22 | 6 | 0 | 44 | 10 | 152 | 10 | 0 | 172 | 775 |
| Total | 186 | 32 | 47 | 0 | 265 | 9 | 1472 | 495 | 0 | 1976 | 57 | 63 | 24 | 1 | 145 | 65 | 703 | 48 | 0 | 816 | 3202 |
| 17:00 | 40 | 6 | 3 | 0 | 49 | 2 | 416 | 192 | 0 | 610 | 17 | 27 | 5 | 1 | 50 | 16 | 197 | 8 | 0 | 221 | 930 |
| 17:15 | 58 | 8 | 11 | 0 | 77 | 3 | 429 | 195 | 0 | 627 | 9 | 28 | 6 | 5 | 48 | 19 | 188 | 10 | 0 | 217 | 969 |
| 17:30 | 40 | 10 | 21 | 0 | 71 | 2 | 328 | 146 | 0 | 476 | 10 | 13 | 2 | 0 | 25 | 10 | 168 | 10 | 0 | 188 | 760 |
| 17:45 | 57 | 10 | 9 | 0 | 76 | 0 | 0 | 0 | 0 | 0 | 0 | 0 | 0 | 0 | 0 | 17 | 152 | 8 | 0 | 177 | 253 |
| Total | 195 | 34 | 44 | 0 | 273 | 7 | 1173 | 533 | 0 | 1713 | 36 | 68 | 13 | 6 | 123 | 62 | 705 | 36 | 0 | 803 | 2912 |
| Grand Total | 2392 | 284 | 444 | 0 | 3120 | 158 | 6038 | 1975 | 1 | 8172 | 363 | 365 | 175 | 32 | 935 | 490 | 8110 | 470 | 0 | 9070 | 21297 |
| Apprch % | 76.7 | 9.1 | 14.2 | 0 | | 1.9 | 73.9 | 24.2 | 0 | | 38.8 | 39 | 18.7 | 3.4 | | 5.4 | 89.4 | 5.2 | 0 | | |
| Total % | 11.2 | 1.3 | 2.1 | 0 | 14.6 | 0.7 | 28.4 | 9.3 | 0 | 38.4 | 1.7 | 1.7 | 0.8 | 0.2 | 4.4 | 2.3 | 38.1 | 2.2 | 0 | 42.6 | |

| CR101 | | | |
|-------|------|-------|------|
| Out | In | Total | |
| 2830 | 3120 | 5950 | |
| 444 | 284 | 2392 | 0 |
| Right | Thru | Left | Peds |

| TH55 | | | |
|------|-------|-------|------|
| Out | In | Total | |
| 6845 | 9070 | 15915 | |
| 0 | 470 | 8110 | 490 |
| Peds | Right | Thru | Left |

| TH55 | | | |
|-------|------|-------|------|
| Out | In | Total | |
| 10677 | 8172 | 18849 | |
| 1975 | 6038 | 158 | 1 |
| Right | Thru | Left | Peds |

North

7/25/2006 06:00
7/25/2006 17:45
Unshifted

| Sioux | | | |
|-------|------|-------|------|
| Left | Thru | Right | Peds |
| 363 | 365 | 175 | 32 |
| 912 | 935 | 1847 | |
| Out | In | Total | |



MINNESOTA DEPT OF TRANSPORTATION

TRAFFIC DATA COLLECTION - METRO

File Name : TH 55 @ CR 101-SIOUX 2006
 Site Code : 07250312
 Start Date : 7/25/2006
 Page No : 3

| Start Time | CR101 Southbound | | | | | TH55 Westbound | | | | | Sioux Northbound | | | | | TH55 Eastbound | | | | | Int. Total |
|--|------------------|------|-------|------|------------|----------------|------|-------|------|------------|------------------|------|-------|------|------------|----------------|------|-------|------|------------|------------|
| | Left | Thru | Right | Peds | App. Total | Left | Thru | Right | Peds | App. Total | Left | Thru | Right | Peds | App. Total | Left | Thru | Right | Peds | App. Total | |
| Peak Hour Analysis From 06:00 to 09:45 - Peak 1 of 1 | | | | | | | | | | | | | | | | | | | | | |
| Peak Hour for Entire Intersection Begins at 06:45 | | | | | | | | | | | | | | | | | | | | | |
| 06:45 | 144 | 21 | 13 | 0 | 178 | 5 | 124 | 41 | 0 | 170 | 5 | 9 | 11 | 0 | 25 | 28 | 439 | 18 | 0 | 485 | 858 |
| 07:00 | 161 | 6 | 21 | 0 | 188 | 6 | 124 | 25 | 0 | 155 | 11 | 10 | 5 | 0 | 26 | 14 | 456 | 12 | 0 | 482 | 851 |
| 07:15 | 185 | 14 | 21 | 0 | 220 | 9 | 105 | 20 | 0 | 134 | 10 | 0 | 3 | 0 | 13 | 13 | 444 | 18 | 0 | 475 | 842 |
| 07:30 | 198 | 16 | 17 | 0 | 231 | 7 | 124 | 22 | 0 | 153 | 7 | 3 | 4 | 0 | 14 | 21 | 456 | 12 | 0 | 489 | 887 |
| Total Volume | 688 | 57 | 72 | 0 | 817 | 27 | 477 | 108 | 0 | 612 | 33 | 22 | 23 | 0 | 78 | 76 | 1795 | 60 | 0 | 1931 | 3438 |
| % App. Total | 84.2 | 7 | 8.8 | 0 | | 4.4 | 77.9 | 17.6 | 0 | | 42.3 | 28.2 | 29.5 | 0 | | 3.9 | 93 | 3.1 | 0 | | |
| PHF | .869 | .679 | .857 | .000 | .884 | .750 | .962 | .659 | .000 | .900 | .750 | .550 | .523 | .000 | .750 | .679 | .984 | .833 | .000 | .987 | .969 |

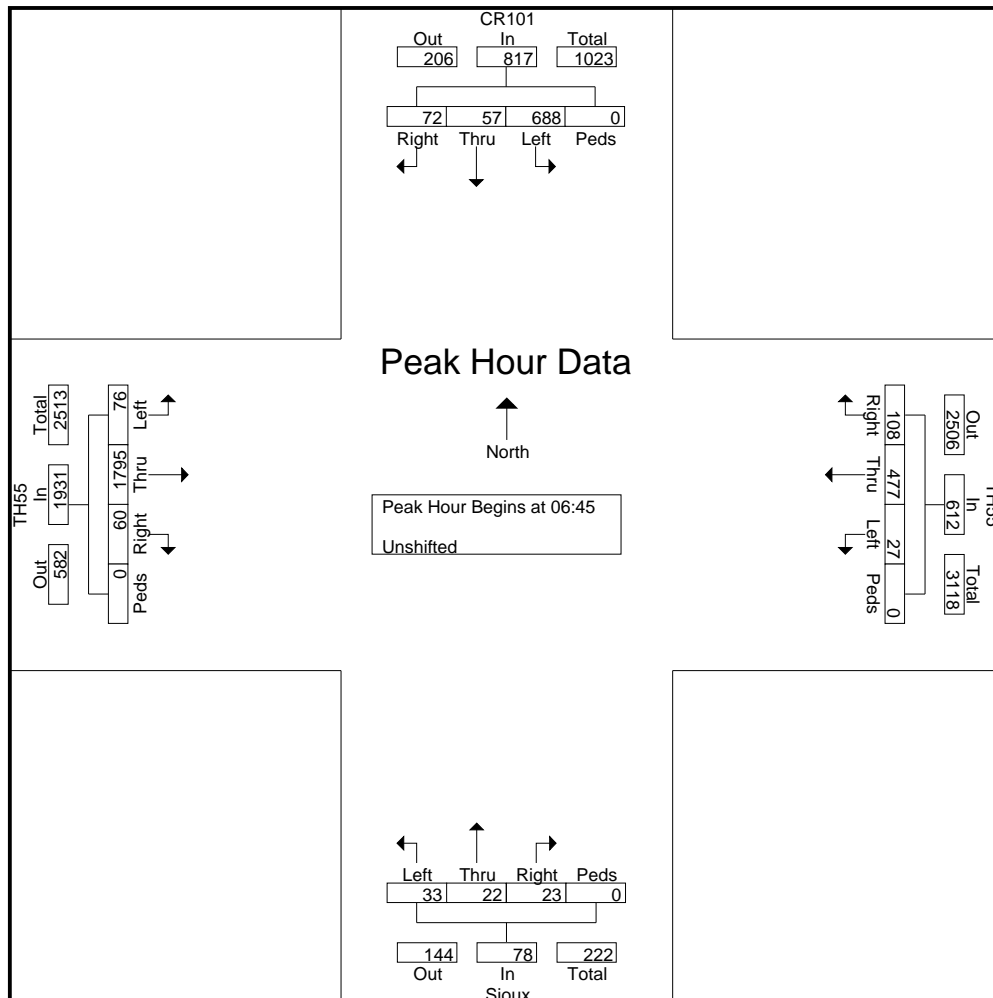



MINNESOTA DEPT OF TRANSPORTATION

TRAFFIC DATA COLLECTION - METRO

File Name : TH 55 @ CR 101-SIOUX 2006
 Site Code : 07250312
 Start Date : 7/25/2006
 Page No : 4

| Start Time | CR101 Southbound | | | | | TH55 Westbound | | | | | Sioux Northbound | | | | | TH55 Eastbound | | | | | Int. Total |
|--------------|------------------|------|-------|------|------------|----------------|------|-------|------|------------|------------------|------|-------|------|------------|----------------|------|-------|------|------------|------------|
| | Left | Thru | Right | Peds | App. Total | Left | Thru | Right | Peds | App. Total | Left | Thru | Right | Peds | App. Total | Left | Thru | Right | Peds | App. Total | |
| 11:45 | 44 | 8 | 15 | 0 | 67 | 5 | 153 | 60 | 0 | 218 | 12 | 7 | 8 | 2 | 29 | 9 | 176 | 18 | 0 | 203 | 517 |
| 12:00 | 47 | 10 | 17 | 0 | 74 | 6 | 130 | 59 | 0 | 195 | 23 | 7 | 8 | 1 | 39 | 20 | 173 | 18 | 0 | 211 | 519 |
| 12:15 | 32 | 7 | 13 | 0 | 52 | 6 | 127 | 53 | 0 | 186 | 10 | 12 | 5 | 2 | 29 | 15 | 202 | 13 | 0 | 230 | 497 |
| 12:30 | 66 | 6 | 14 | 0 | 86 | 16 | 152 | 35 | 0 | 203 | 15 | 10 | 2 | 1 | 28 | 24 | 158 | 24 | 0 | 206 | 523 |
| Total Volume | 189 | 31 | 59 | 0 | 279 | 33 | 562 | 207 | 0 | 802 | 60 | 36 | 23 | 6 | 125 | 68 | 709 | 73 | 0 | 850 | 2056 |
| % App. Total | 67.7 | 11.1 | 21.1 | 0 | | 4.1 | 70.1 | 25.8 | 0 | | 48 | 28.8 | 18.4 | 4.8 | | 8 | 83.4 | 8.6 | 0 | | |
| PHF | .716 | .775 | .868 | .000 | .811 | .516 | .918 | .863 | .000 | .920 | .652 | .750 | .719 | .750 | .801 | .708 | .877 | .760 | .000 | .924 | .983 |

Peak Hour Analysis From 10:00 to 13:45 - Peak 1 of 1
 Peak Hour for Entire Intersection Begins at 11:45

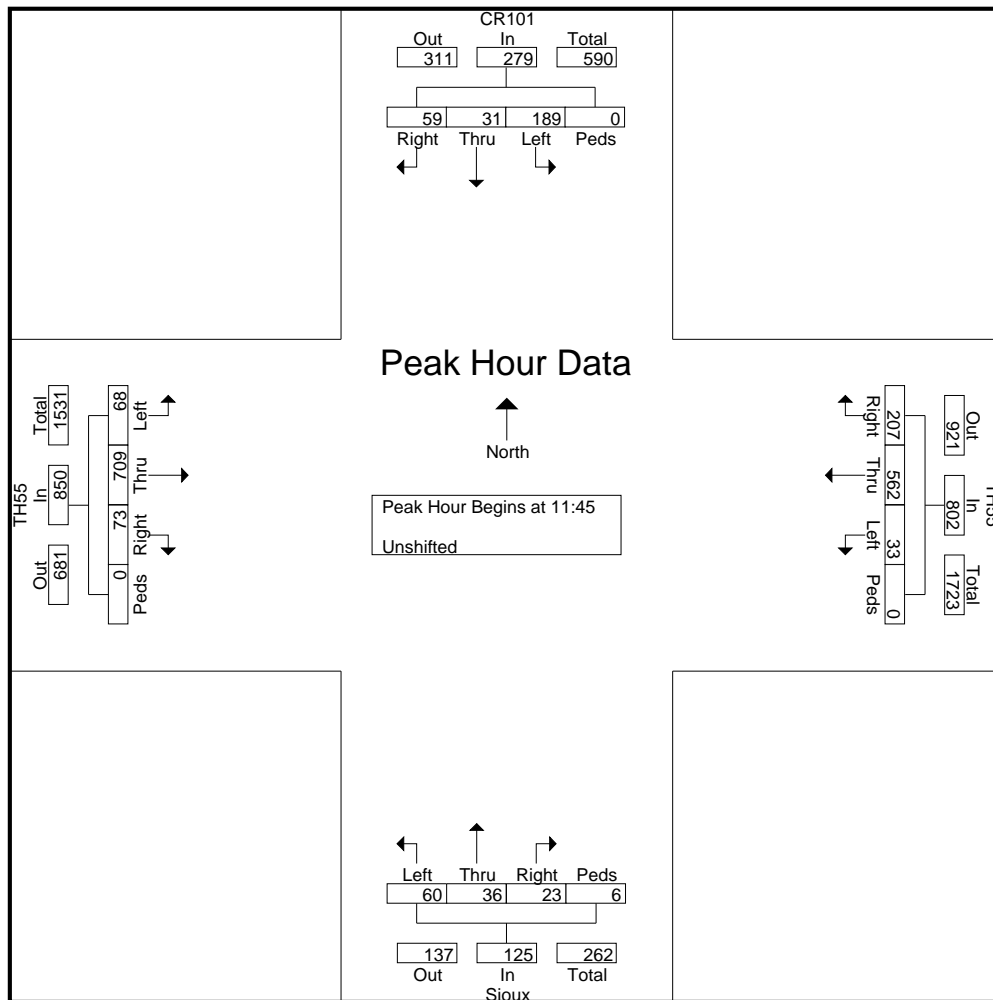



MINNESOTA DEPT OF TRANSPORTATION

TRAFFIC DATA COLLECTION - METRO

File Name : TH 55 @ CR 101-SIOUX 2006
 Site Code : 07250312
 Start Date : 7/25/2006
 Page No : 5

| Start Time | CR101 Southbound | | | | | TH55 Westbound | | | | | Sioux Northbound | | | | | TH55 Eastbound | | | | | Int. Total |
|--------------|------------------|------|-------|------|------------|----------------|------|-------|------|------------|------------------|------|-------|------|------------|----------------|------|-------|------|------------|------------|
| | Left | Thru | Right | Peds | App. Total | Left | Thru | Right | Peds | App. Total | Left | Thru | Right | Peds | App. Total | Left | Thru | Right | Peds | App. Total | |
| 16:30 | 49 | 3 | 16 | 0 | 68 | 2 | 332 | 145 | 0 | 479 | 6 | 16 | 1 | 0 | 23 | 24 | 184 | 11 | 0 | 219 | 789 |
| 16:45 | 50 | 5 | 7 | 0 | 62 | 5 | 375 | 117 | 0 | 497 | 16 | 22 | 6 | 0 | 44 | 10 | 152 | 10 | 0 | 172 | 775 |
| 17:00 | 40 | 6 | 3 | 0 | 49 | 2 | 416 | 192 | 0 | 610 | 17 | 27 | 5 | 1 | 50 | 16 | 197 | 8 | 0 | 221 | 930 |
| 17:15 | 58 | 8 | 11 | 0 | 77 | 3 | 429 | 195 | 0 | 627 | 9 | 28 | 6 | 5 | 48 | 19 | 188 | 10 | 0 | 217 | 969 |
| Total Volume | 197 | 22 | 37 | 0 | 256 | 12 | 1552 | 649 | 0 | 2213 | 48 | 93 | 18 | 6 | 165 | 69 | 721 | 39 | 0 | 829 | 3463 |
| % App. Total | 77 | 8.6 | 14.5 | 0 | | 0.5 | 70.1 | 29.3 | 0 | | 29.1 | 56.4 | 10.9 | 3.6 | | 8.3 | 87 | 4.7 | 0 | | |
| PHF | .849 | .688 | .578 | .000 | .831 | .600 | .904 | .832 | .000 | .882 | .706 | .830 | .750 | .300 | .825 | .719 | .915 | .886 | .000 | .938 | .893 |

Peak Hour Analysis From 14:00 to 17:45 - Peak 1 of 1
 Peak Hour for Entire Intersection Begins at 16:30

