

Alliant Engineering Inc Minneapolis, MN 55415

TH-55 at Arrowhead Drive
Ref.Pt.: 174.463
Alliant Engineering Inc
TURN MOVEMENT COUNT

File Name : 30_TH 55 at Arrowhead Dr_012711
Site Code : 00000030
Start Date : 1/27/2011
Page No : 1

Groups Printed- Unshifted - Bank 1

Start Time	Arrowhead Drive Southbound				TH-55 Westbound				Arrowhead Drive Northbound				TH-55 Eastbound				Int. Total
	Left	Thru	Right	Peds	Left	Thru	Right	Peds	Left	Thru	Right	Peds	Left	Thru	Right	Peds	
06:00	0	0	0	0	12	25	1	0	1	0	0	0	0	202	4	0	245
06:15	3	0	0	0	23	52	8	0	0	0	1	0	1	241	3	0	332
06:30	4	0	0	0	27	65	16	0	1	0	3	0	1	288	14	0	419
06:45	1	1	0	0	26	68	18	0	1	1	5	0	4	255	9	0	389
Total	8	1	0	0	88	210	43	0	3	1	9	0	6	986	30	0	1385
07:00	6	4	2	0	17	54	3	0	3	0	2	0	0	286	2	0	379
07:15	13	4	0	0	22	79	4	0	0	1	2	0	1	295	6	0	427
07:30	3	3	1	0	16	108	2	0	1	0	6	0	0	319	8	0	467
07:45	6	2	1	0	22	91	3	0	9	2	10	0	1	218	12	0	377
Total	28	13	4	0	77	332	12	0	13	3	20	0	2	1118	28	0	1650
08:00	3	0	0	0	28	92	4	0	1	2	7	0	0	247	7	0	391
08:15	7	1	0	0	17	78	1	0	1	0	9	0	0	182	10	0	306
08:30	9	2	1	0	14	58	2	0	0	0	5	0	1	162	2	0	256
08:45	4	0	0	0	17	63	3	0	1	0	7	0	0	154	5	0	254
Total	23	3	1	0	76	291	10	0	3	2	28	0	1	745	24	0	1207
09:00	1	1	1	0	14	54	2	0	1	1	5	0	0	127	0	0	207
09:15	2	1	0	0	10	58	3	0	1	0	7	0	0	96	1	0	179
*** BREAK ***																	
Total	3	2	1	0	24	112	5	0	2	1	12	0	0	223	1	0	386
*** BREAK ***																	
10:30	2	0	0	0	7	78	3	0	3	0	8	0	0	98	0	1	200
10:45	7	0	0	0	7	78	3	0	1	0	9	0	0	89	1	0	195
Total	9	0	0	0	14	156	6	0	4	0	17	0	0	187	1	1	395
11:00	7	0	0	0	5	73	6	0	2	2	7	0	0	90	0	0	192
11:15	8	0	2	0	8	72	2	0	5	1	7	0	2	87	1	0	195
11:30	2	1	2	0	6	79	2	0	0	0	9	0	0	102	0	0	203
11:45	6	0	0	0	11	96	6	0	2	0	15	0	0	95	1	0	232
Total	23	1	4	0	30	320	16	0	9	3	38	0	2	374	2	0	822
12:00	6	0	1	0	14	100	12	0	2	0	28	0	0	96	1	0	260
12:15	2	1	1	0	14	92	5	0	4	1	15	0	2	99	0	0	236
12:30	4	1	0	0	12	114	3	0	4	0	10	0	0	89	0	0	237
12:45	4	0	1	0	20	129	5	0	3	2	4	0	1	97	2	0	268
Total	16	2	3	0	60	435	25	0	13	3	57	0	3	381	3	0	1001
13:00	2	0	0	0	14	99	2	0	1	1	12	1	0	77	3	0	212
13:15	4	1	0	0	9	99	0	0	2	0	7	0	0	90	1	0	213
*** BREAK ***																	
Total	6	1	0	0	23	198	2	0	3	1	19	1	0	167	4	0	425
*** BREAK ***																	
14:30	5	0	0	0	8	154	7	0	5	0	11	0	0	82	0	0	272
14:45	2	0	0	0	11	156	3	0	4	0	8	0	0	60	1	0	245
Total	7	0	0	0	19	310	10	0	9	0	19	0	0	142	1	0	517
15:00	15	2	0	0	5	175	1	0	2	0	10	0	0	88	1	0	299
15:15	21	0	2	0	14	196	7	0	5	1	16	0	0	94	1	0	357
15:30	6	1	1	0	12	245	5	0	13	0	25	0	0	85	4	0	397
15:45	1	0	0	0	6	250	5	0	5	1	13	0	0	101	1	0	383
Total	43	3	3	0	37	866	18	0	25	2	64	0	0	368	7	0	1436

Alliant Engineering Inc Minneapolis, MN 55415

TH-55 at Arrowhead Drive
Ref.Pt.: 174.463
Alliant Engineering Inc
TURN MOVEMENT COUNT

File Name : 30_TH 55 at Arrowhead Dr_012711
Site Code : 00000030
Start Date : 1/27/2011
Page No : 2

Groups Printed- Unshifted - Bank 1

Start Time	Arrowhead Drive Southbound				TH-55 Westbound				Arrowhead Drive Northbound				TH-55 Eastbound				Int. Total
	Left	Thru	Right	Peds	Left	Thru	Right	Peds	Left	Thru	Right	Peds	Left	Thru	Right	Peds	
16:00	2	0	0	0	7	263	4	0	8	1	20	0	0	67	2	0	374
16:15	1	1	1	0	4	236	5	0	5	0	17	0	0	100	1	0	371
16:30	2	0	0	0	4	315	4	0	18	1	53	0	0	123	1	0	521
16:45	1	4	0	0	5	300	4	0	7	1	18	0	1	104	0	0	445
Total	6	5	1	0	20	1114	17	0	38	3	108	0	1	394	4	0	1711
17:00	4	0	0	0	4	246	6	0	6	1	24	0	2	115	1	0	409
17:15	6	0	2	0	4	342	5	0	6	0	18	0	0	128	1	0	512
17:30	4	1	1	0	5	253	4	0	4	1	11	0	0	89	0	0	373
17:45	3	0	1	0	4	213	6	0	0	0	5	0	0	74	2	0	308
Total	17	1	4	0	17	1054	21	0	16	2	58	0	2	406	4	0	1602
Grand Total	189	32	21	0	485	5398	185	0	138	21	449	1	17	5491	109	1	12537
Apprch %	78.1	13.2	8.7	0	8	89	3	0	22.7	3.4	73.7	0.2	0.3	97.7	1.9	0	
Total %	1.5	0.3	0.2	0	3.9	43.1	1.5	0	1.1	0.2	3.6	0	0.1	43.8	0.9	0	
Unshifted	181	31	17	0	451	5304	174	0	124	19	426	1	17	5392	107	1	12245
% Unshifted	95.8	96.9	81	0	93	98.3	94.1	0	89.9	90.5	94.9	100	100	98.2	98.2	100	97.7
Bank 1	8	1	4	0	34	94	11	0	14	2	23	0	0	99	2	0	292
% Bank 1	4.2	3.1	19	0	7	1.7	5.9	0	10.1	9.5	5.1	0	0	1.8	1.8	0	2.3

Alliant Engineering Inc Minneapolis, MN 55415

TH-55 at Arrowhead Drive
Ref.Pt.: 174.463
Alliant Engineering Inc
TURN MOVEMENT COUNT

File Name : 30_TH 55 at Arrowhead Dr_012711
Site Code : 00000030
Start Date : 1/27/2011
Page No : 3

Start Time	Arrowhead Drive Southbound					TH-55 Westbound					Arrowhead Drive Northbound					TH-55 Eastbound					Int. Total
	Left	Thru	Right	Peds	App. Total	Left	Thru	Right	Peds	App. Total	Left	Thru	Right	Peds	App. Total	Left	Thru	Right	Peds	App. Total	
Peak Hour Analysis From 06:00 to 09:15 - Peak 1 of 1																					
Peak Hour for Entire Intersection Begins at 06:45																					
06:45	1	1	0	0	2	26	68	18	0	112	1	1	5	0	7	4	255	9	0	268	389
07:00	6	4	2	0	12	17	54	3	0	74	3	0	2	0	5	0	286	2	0	288	379
07:15	13	4	0	0	17	22	79	4	0	105	0	1	2	0	3	1	295	6	0	302	427
07:30	3	3	1	0	7	16	108	2	0	126	1	0	6	0	7	0	319	8	0	327	467
Total Volume	23	12	3	0	38	81	309	27	0	417	5	2	15	0	22	5	1155	25	0	1185	1662
% App. Total	60.5	31.6	7.9	0		19.4	74.1	6.5	0		22.7	9.1	68.2	0		0.4	97.5	2.1	0		
PHF	.442	.750	.375	.000	.559	.779	.715	.375	.000	.827	.417	.500	.625	.000	.786	.313	.905	.694	.000	.906	.890

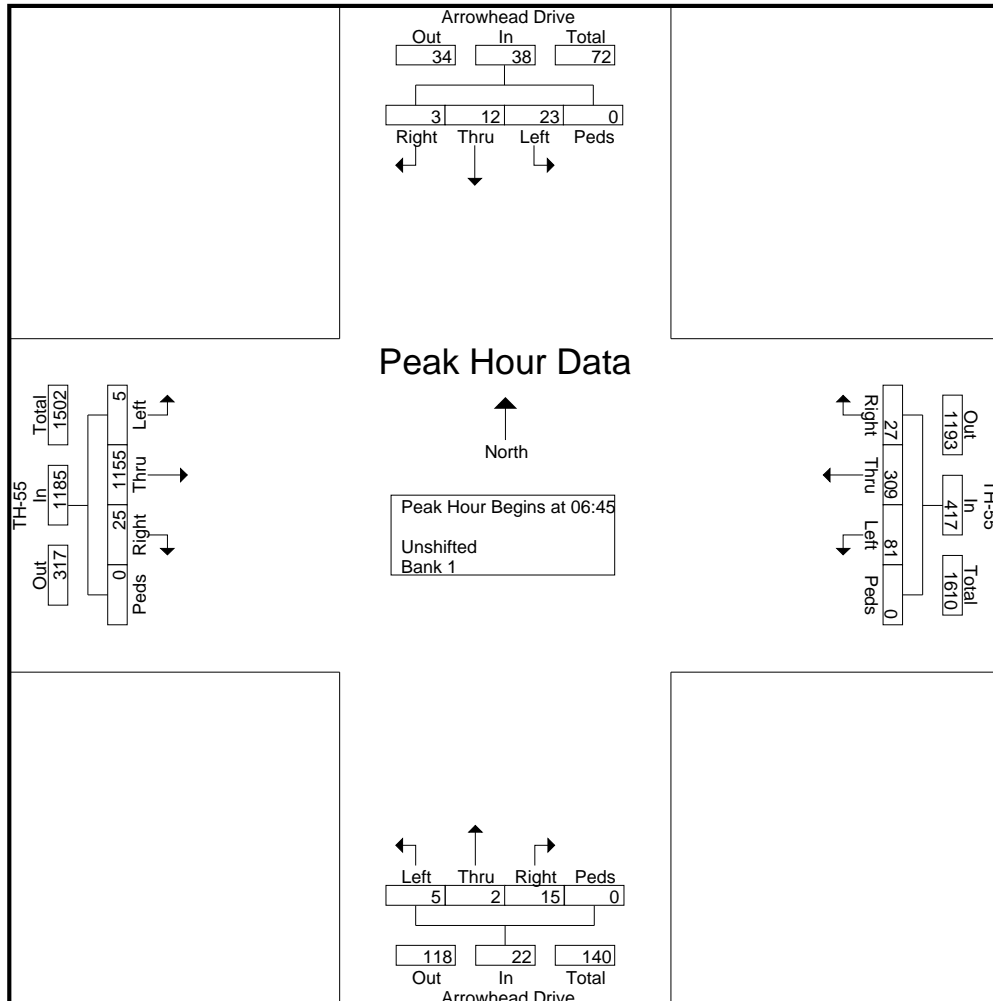

Alliant Engineering Inc Minneapolis, MN 55415

TH-55 at Arrowhead Drive
 Ref.Pt.: 174.463
 Alliant Engineering Inc
 TURN MOVEMENT COUNT

File Name : 30_TH 55 at Arrowhead Dr_012711
 Site Code : 00000030
 Start Date : 1/27/2011
 Page No : 4

Start Time	Arrowhead Drive Southbound					TH-55 Westbound					Arrowhead Drive Northbound					TH-55 Eastbound					Int. Total
	Left	Thru	Right	Peds	App. Total	Left	Thru	Right	Peds	App. Total	Left	Thru	Right	Peds	App. Total	Left	Thru	Right	Peds	App. Total	
Peak Hour Analysis From 14:30 to 17:45 - Peak 1 of 1																					
Peak Hour for Entire Intersection Begins at 16:30																					
16:30	2	0	0	0	2	4	315	4	0	323	18	1	53	0	72	0	123	1	0	124	521
16:45	1	4	0	0	5	5	300	4	0	309	7	1	18	0	26	1	104	0	0	105	445
17:00	4	0	0	0	4	4	246	6	0	256	6	1	24	0	31	2	115	1	0	118	409
17:15	6	0	2	0	8	4	342	5	0	351	6	0	18	0	24	0	128	1	0	129	512
Total Volume	13	4	2	0	19	17	1203	19	0	1239	37	3	113	0	153	3	470	3	0	476	1887
% App. Total	68.4	21.1	10.5	0		1.4	97.1	1.5	0		24.2	2	73.9	0		0.6	98.7	0.6	0		
PHF	.542	.250	.250	.000	.594	.850	.879	.792	.000	.882	.514	.750	.533	.000	.531	.375	.918	.750	.000	.922	.905

