

# ALLIANT ENGINEERING, INC.

733 S Marquette Ave #700, Minneapolis, MN 55402

CSAH 23 (CR C) & Lincoln Dr  
 City: Roseville  
 data by: Alliant Engineering, Inc.  
 TURN MOVEMENT COUNT

File Name : CSAH 23 (CR C) & Lincoln Dr\_2021  
 Site Code : 110  
 Start Date : 10/13/2021  
 Page No : 1

Groups Printed- Cars - Trucks

Start Time	Lincoln Dr Southbound					CSAH 23 (CR C) Westbound					Northbound					CSAH 23 (CR C) Eastbound					Int. Total
	Left	Thru	Right	Peds	App. Total	Left	Thru	Right	Peds	App. Total	Left	Thru	Right	Peds	App. Total	Left	Thru	Right	Peds	App. Total	
06:00 AM	5	0	0	0	5	0	40	8	0	48	0	0	0	0	0	2	8	0	0	10	63
06:15 AM	7	0	2	0	9	0	48	18	0	66	0	0	0	0	0	3	25	0	0	28	103
06:30 AM	4	0	3	0	7	0	54	28	0	82	0	0	0	0	0	6	38	0	1	45	134
06:45 AM	6	0	6	0	12	0	79	26	0	105	0	0	0	0	0	5	32	0	0	37	154
<b>Total</b>	<b>22</b>	<b>0</b>	<b>11</b>	<b>0</b>	<b>33</b>	<b>0</b>	<b>221</b>	<b>80</b>	<b>0</b>	<b>301</b>	<b>0</b>	<b>0</b>	<b>0</b>	<b>0</b>	<b>0</b>	<b>16</b>	<b>103</b>	<b>0</b>	<b>1</b>	<b>120</b>	<b>454</b>
07:00 AM	10	0	3	0	13	0	77	19	0	96	0	0	0	0	0	9	24	0	0	33	142
07:15 AM	20	0	3	0	23	0	82	25	0	107	0	0	0	0	0	7	59	0	0	66	196
07:30 AM	15	0	11	0	26	0	99	15	0	114	0	0	0	0	0	9	44	0	0	53	193
07:45 AM	8	0	12	0	20	0	98	40	0	138	0	0	0	0	0	12	55	0	1	68	226
<b>Total</b>	<b>53</b>	<b>0</b>	<b>29</b>	<b>0</b>	<b>82</b>	<b>0</b>	<b>356</b>	<b>99</b>	<b>0</b>	<b>455</b>	<b>0</b>	<b>0</b>	<b>0</b>	<b>0</b>	<b>0</b>	<b>37</b>	<b>182</b>	<b>0</b>	<b>1</b>	<b>220</b>	<b>757</b>
08:00 AM	18	0	7	1	26	0	114	42	0	156	0	0	0	0	0	12	66	0	0	78	260
08:15 AM	17	0	10	1	28	0	82	31	0	113	0	0	0	0	0	4	44	0	0	48	189
08:30 AM	14	0	7	0	21	0	79	38	0	117	0	0	0	0	0	11	63	0	0	74	212
08:45 AM	21	0	6	0	27	0	75	54	0	129	0	0	0	0	0	16	79	0	0	95	251
<b>Total</b>	<b>70</b>	<b>0</b>	<b>30</b>	<b>2</b>	<b>102</b>	<b>0</b>	<b>350</b>	<b>165</b>	<b>0</b>	<b>515</b>	<b>0</b>	<b>0</b>	<b>0</b>	<b>0</b>	<b>0</b>	<b>43</b>	<b>252</b>	<b>0</b>	<b>0</b>	<b>295</b>	<b>912</b>
09:00 AM	22	0	11	0	33	0	85	39	0	124	0	0	0	0	0	15	53	0	0	68	225
09:15 AM	22	0	14	0	36	0	87	40	0	127	0	0	0	0	0	7	63	0	0	70	233
*** BREAK ***																					
<b>Total</b>	<b>44</b>	<b>0</b>	<b>25</b>	<b>0</b>	<b>69</b>	<b>0</b>	<b>172</b>	<b>79</b>	<b>0</b>	<b>251</b>	<b>0</b>	<b>0</b>	<b>0</b>	<b>0</b>	<b>0</b>	<b>22</b>	<b>116</b>	<b>0</b>	<b>0</b>	<b>138</b>	<b>458</b>
*** BREAK ***																					
10:30 AM	25	0	14	0	39	0	83	43	0	126	0	0	0	0	0	15	91	0	0	106	271
10:45 AM	46	0	21	0	67	0	113	52	0	165	0	0	0	0	0	12	101	0	0	113	345
<b>Total</b>	<b>71</b>	<b>0</b>	<b>35</b>	<b>0</b>	<b>106</b>	<b>0</b>	<b>196</b>	<b>95</b>	<b>0</b>	<b>291</b>	<b>0</b>	<b>0</b>	<b>0</b>	<b>0</b>	<b>0</b>	<b>27</b>	<b>192</b>	<b>0</b>	<b>0</b>	<b>219</b>	<b>616</b>
11:00 AM	36	0	21	0	57	0	95	55	0	150	0	0	0	0	0	15	107	0	0	122	329
11:15 AM	40	0	31	1	72	0	102	64	0	166	0	0	0	0	0	18	116	0	0	134	372
11:30 AM	49	0	18	0	67	0	111	67	0	178	0	0	0	0	0	25	105	0	0	130	375
11:45 AM	61	0	37	0	98	0	115	44	0	159	0	0	0	0	0	19	95	0	0	114	371
<b>Total</b>	<b>186</b>	<b>0</b>	<b>107</b>	<b>1</b>	<b>294</b>	<b>0</b>	<b>423</b>	<b>230</b>	<b>0</b>	<b>653</b>	<b>0</b>	<b>0</b>	<b>0</b>	<b>0</b>	<b>0</b>	<b>77</b>	<b>423</b>	<b>0</b>	<b>0</b>	<b>500</b>	<b>1447</b>
12:00 PM	61	0	31	0	92	0	120	54	0	174	0	0	0	0	0	30	129	0	1	160	426
12:15 PM	62	0	19	0	81	0	109	70	0	179	0	0	0	0	0	22	125	0	0	147	407
12:30 PM	60	0	21	0	81	0	131	64	0	195	0	0	0	0	0	28	111	0	0	139	415
12:45 PM	56	0	28	0	84	0	133	62	0	195	0	0	0	0	0	20	111	0	0	131	410
<b>Total</b>	<b>239</b>	<b>0</b>	<b>99</b>	<b>0</b>	<b>338</b>	<b>0</b>	<b>493</b>	<b>250</b>	<b>0</b>	<b>743</b>	<b>0</b>	<b>0</b>	<b>0</b>	<b>0</b>	<b>0</b>	<b>100</b>	<b>476</b>	<b>0</b>	<b>1</b>	<b>577</b>	<b>1658</b>
01:00 PM	53	0	19	1	73	0	104	55	0	159	0	0	0	0	0	23	107	0	0	130	362
01:15 PM	57	0	30	1	88	0	110	59	0	169	0	0	0	0	0	18	115	0	0	133	390
*** BREAK ***																					
<b>Total</b>	<b>110</b>	<b>0</b>	<b>49</b>	<b>2</b>	<b>161</b>	<b>0</b>	<b>214</b>	<b>114</b>	<b>0</b>	<b>328</b>	<b>0</b>	<b>0</b>	<b>0</b>	<b>0</b>	<b>0</b>	<b>41</b>	<b>222</b>	<b>0</b>	<b>0</b>	<b>263</b>	<b>752</b>
*** BREAK ***																					
02:30 PM	51	0	13	1	65	0	91	45	0	136	0	0	0	0	0	15	120	0	0	135	336
02:45 PM	45	0	16	0	61	0	97	44	0	141	0	0	0	0	0	28	129	0	0	157	359
<b>Total</b>	<b>96</b>	<b>0</b>	<b>29</b>	<b>1</b>	<b>126</b>	<b>0</b>	<b>188</b>	<b>89</b>	<b>0</b>	<b>277</b>	<b>0</b>	<b>0</b>	<b>0</b>	<b>0</b>	<b>0</b>	<b>43</b>	<b>249</b>	<b>0</b>	<b>0</b>	<b>292</b>	<b>695</b>
03:00 PM	62	0	21	0	83	0	95	63	0	158	0	0	0	0	0	14	150	0	0	164	405
03:15 PM	47	0	18	0	65	0	115	48	0	163	0	0	0	0	0	14	145	0	0	159	387
03:30 PM	38	0	25	0	63	0	98	46	0	144	0	0	0	0	0	18	171	0	1	190	397
03:45 PM	39	0	16	0	55	0	79	32	0	111	0	0	0	0	0	22	166	0	0	188	354
<b>Total</b>	<b>186</b>	<b>0</b>	<b>80</b>	<b>0</b>	<b>266</b>	<b>0</b>	<b>387</b>	<b>189</b>	<b>0</b>	<b>576</b>	<b>0</b>	<b>0</b>	<b>0</b>	<b>0</b>	<b>0</b>	<b>68</b>	<b>632</b>	<b>0</b>	<b>1</b>	<b>701</b>	<b>1543</b>

# ALLIANT ENGINEERING, INC.

733 S Marquette Ave #700, Minneapolis, MN 55402

CSAH 23 (CR C) & Lincoln Dr  
 City: Roseville  
 data by: Alliant Engineering, Inc.  
 TURN MOVEMENT COUNT

File Name : CSAH 23 (CR C) & Lincoln Dr\_2021  
 Site Code : 110  
 Start Date : 10/13/2021  
 Page No : 2

Groups Printed- Cars - Trucks

Start Time	Lincoln Dr Southbound					CSAH 23 (CR C) Westbound					Northbound					CSAH 23 (CR C) Eastbound					Int. Total
	Left	Thru	Right	Peds	App. Total	Left	Thru	Right	Peds	App. Total	Left	Thru	Right	Peds	App. Total	Left	Thru	Right	Peds	App. Total	
04:00 PM	38	0	18	0	56	0	91	40	0	131	0	0	0	0	0	14	171	0	0	185	372
04:15 PM	34	0	23	0	57	0	101	56	0	157	0	0	0	0	0	24	149	0	1	174	388
04:30 PM	45	0	18	0	63	0	92	38	0	130	0	0	0	0	0	30	163	0	0	193	386
04:45 PM	52	0	29	0	81	0	113	46	0	159	0	0	0	0	0	19	160	0	0	179	419
Total	169	0	88	0	257	0	397	180	0	577	0	0	0	0	0	87	643	0	1	731	1565
05:00 PM	57	0	23	0	80	0	86	55	0	141	0	0	0	0	0	27	188	0	0	215	436
05:15 PM	42	0	14	3	59	0	93	48	0	141	0	0	0	0	0	21	161	0	0	182	382
05:30 PM	57	0	15	1	73	0	92	44	0	136	0	0	0	0	0	23	136	0	0	159	368
05:45 PM	48	0	19	0	67	0	68	48	0	116	0	0	0	0	0	14	104	0	0	118	301
Total	204	0	71	4	279	0	339	195	0	534	0	0	0	0	0	85	589	0	0	674	1487
06:00 PM	42	0	12	1	55	0	82	47	0	129	0	0	0	0	0	11	95	0	0	106	290
06:15 PM	65	0	15	2	82	0	84	40	0	124	0	0	0	0	0	12	93	0	1	106	312
Grand Total	1557	0	680	13	2250	0	3902	1852	0	5754	0	0	0	0	0	669	4267	0	6	4942	12946
Apprch %	69.2	0	30.2	0.6		0	67.8	32.2	0		0	0	0	0		13.5	86.3	0	0.1		
Total %	12	0	5.3	0.1	17.4	0	30.1	14.3	0	44.4	0	0	0	0	0	5.2	33	0	0	38.2	
Cars	1521	0	663	6	2190	0	3773	1814	0	5587	0	0	0	0	0	651	4129	0	5	4785	12562
% Cars	97.7	0	97.5	46.2	97.3	0	96.7	97.9	0	97.1	0	0	0	0	0	97.3	96.8	0	83.3	96.8	97
Trucks	36	0	17	7	60	0	129	38	0	167	0	0	0	0	0	18	138	0	1	157	384
% Trucks	2.3	0	2.5	53.8	2.7	0	3.3	2.1	0	2.9	0	0	0	0	0	2.7	3.2	0	16.7	3.2	3

# ALLIANT ENGINEERING, INC.

733 S Marquette Ave #700, Minneapolis, MN 55402

CSAH 23 (CR C) & Lincoln Dr  
 City: Roseville  
 data by: Alliant Engineering, Inc.  
 TURN MOVEMENT COUNT

File Name : CSAH 23 (CR C) & Lincoln Dr\_2021  
 Site Code : 110  
 Start Date : 10/13/2021  
 Page No : 3

Start Time	Lincoln Dr Southbound					CSAH 23 (CR C) Westbound					Northbound					CSAH 23 (CR C) Eastbound					Int. Total
	Left	Thru	Right	Peds	App. Total	Left	Thru	Right	Peds	App. Total	Left	Thru	Right	Peds	App. Total	Left	Thru	Right	Peds	App. Total	
Peak Hour Analysis From 06:00 AM to 09:45 AM - Peak 1 of 1																					
Peak Hour for Entire Intersection Begins at 08:30 AM																					
08:30 AM	14	0	7	0	21	0	79	38	0	117	0	0	0	0	0	11	63	0	0	74	212
08:45 AM	21	0	6	0	27	0	75	<b>54</b>	0	<b>129</b>	0	0	0	0	0	<b>16</b>	<b>79</b>	0	0	<b>95</b>	<b>251</b>
09:00 AM	<b>22</b>	0	11	0	33	0	85	39	0	124	0	0	0	0	0	15	53	0	0	68	225
09:15 AM	22	0	<b>14</b>	0	<b>36</b>	0	<b>87</b>	40	0	127	0	0	0	0	0	7	63	0	0	70	233
Total Volume	79	0	38	0	117	0	326	171	0	497	0	0	0	0	0	49	258	0	0	307	921
% App. Total	67.5	0	32.5	0		0	65.6	34.4	0		0	0	0	0		16	84	0	0		
PHF	.898	.000	.679	.000	.813	.000	.937	.792	.000	.963	.000	.000	.000	.000	.000	.766	.816	.000	.000	.808	.917

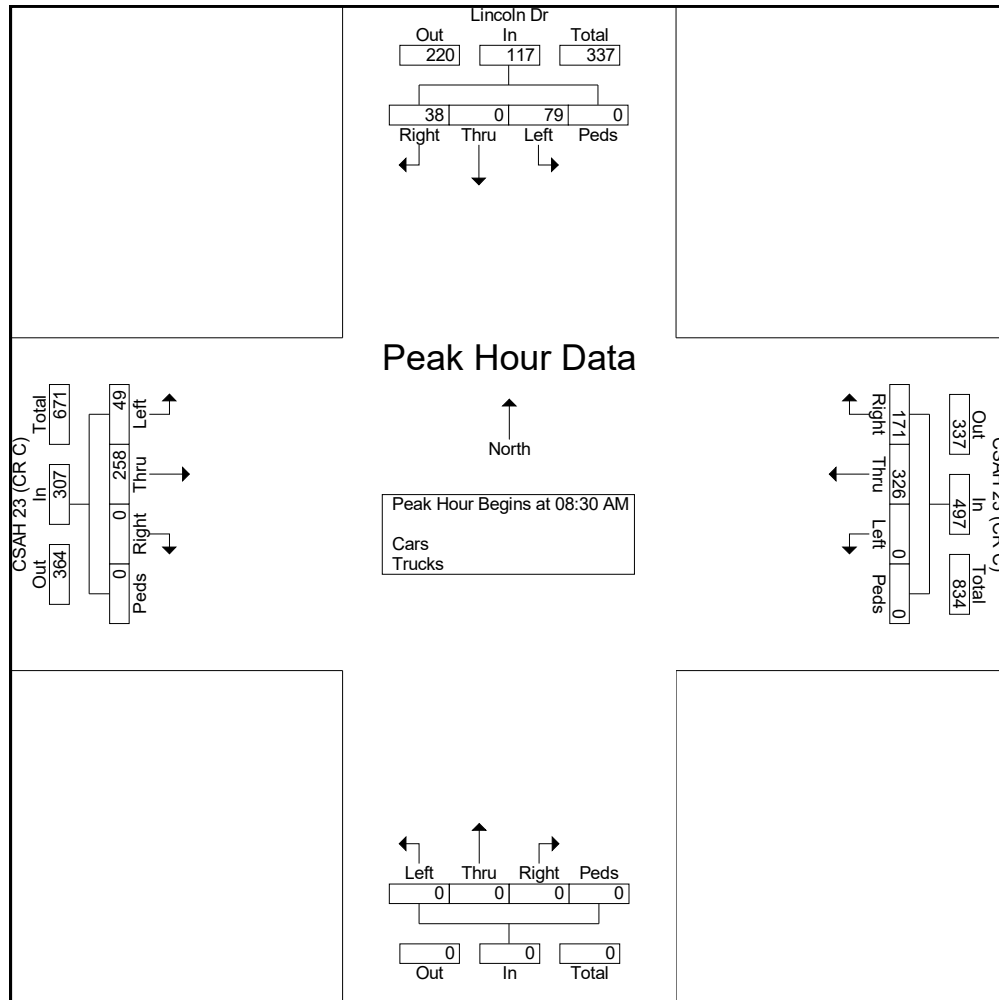

# ALLIANT ENGINEERING, INC.

733 S Marquette Ave #700, Minneapolis, MN 55402

CSAH 23 (CR C) & Lincoln Dr  
 City: Roseville  
 data by: Alliant Engineering, Inc.  
 TURN MOVEMENT COUNT

File Name : CSAH 23 (CR C) & Lincoln Dr\_2021  
 Site Code : 110  
 Start Date : 10/13/2021  
 Page No : 4

Start Time	Lincoln Dr Southbound					CSAH 23 (CR C) Westbound					Northbound					CSAH 23 (CR C) Eastbound					Int. Total
	Left	Thru	Right	Peds	App. Total	Left	Thru	Right	Peds	App. Total	Left	Thru	Right	Peds	App. Total	Left	Thru	Right	Peds	App. Total	
Peak Hour Analysis From 10:00 AM to 01:45 PM - Peak 1 of 1																					
Peak Hour for Entire Intersection Begins at 12:00 PM																					
12:00 PM	61	0	31	0	92	0	120	54	0	174	0	0	0	0	0	30	129	0	1	160	426
12:15 PM	62	0	19	0	81	0	109	70	0	179	0	0	0	0	0	22	125	0	0	147	407
12:30 PM	60	0	21	0	81	0	131	64	0	195	0	0	0	0	0	28	111	0	0	139	415
12:45 PM	56	0	28	0	84	0	133	62	0	195	0	0	0	0	0	20	111	0	0	131	410
Total Volume	239	0	99	0	338	0	493	250	0	743	0	0	0	0	0	100	476	0	1	577	1658
% App. Total	70.7	0	29.3	0		0	66.4	33.6	0		0	0	0	0		17.3	82.5	0	0.2		
PHF	.964	.000	.798	.000	.918	.000	.927	.893	.000	.953	.000	.000	.000	.000	.000	.833	.922	.000	.250	.902	.973

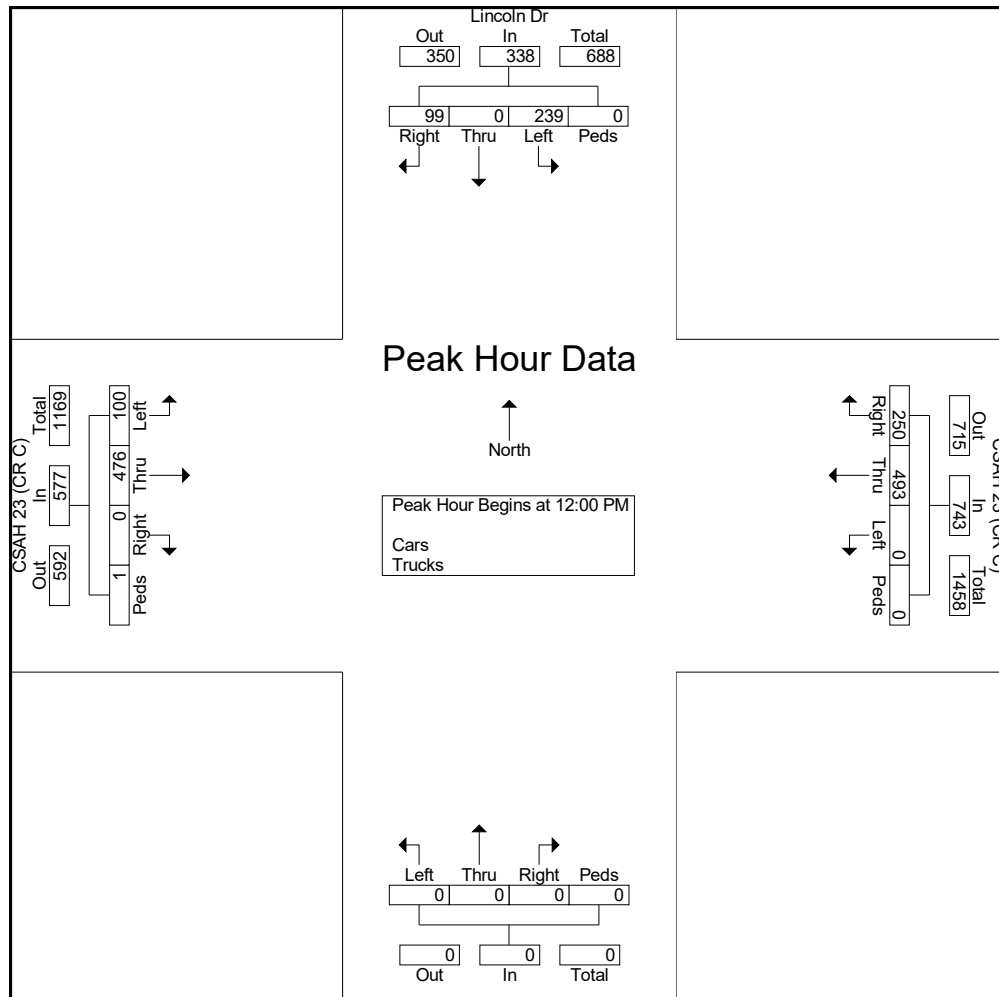

# ALLIANT ENGINEERING, INC.

733 S Marquette Ave #700, Minneapolis, MN 55402

CSAH 23 (CR C) & Lincoln Dr  
 City: Roseville  
 data by: Alliant Engineering, Inc.  
 TURN MOVEMENT COUNT

File Name : CSAH 23 (CR C) & Lincoln Dr\_2021  
 Site Code : 110  
 Start Date : 10/13/2021  
 Page No : 5

Start Time	Lincoln Dr Southbound					CSAH 23 (CR C) Westbound					Northbound					CSAH 23 (CR C) Eastbound					Int. Total
	Left	Thru	Right	Peds	App. Total	Left	Thru	Right	Peds	App. Total	Left	Thru	Right	Peds	App. Total	Left	Thru	Right	Peds	App. Total	
Peak Hour Analysis From 02:00 PM to 06:15 PM - Peak 1 of 1																					
Peak Hour for Entire Intersection Begins at 04:15 PM																					
04:15 PM	34	0	23	0	57	0	101	56	0	157	0	0	0	0	0	24	149	0	1	174	388
04:30 PM	45	0	18	0	63	0	92	38	0	130	0	0	0	0	0	30	163	0	0	193	386
04:45 PM	52	0	29	0	81	0	113	46	0	159	0	0	0	0	0	19	160	0	0	179	419
05:00 PM	57	0	23	0	80	0	86	55	0	141	0	0	0	0	0	27	188	0	0	215	436
Total Volume	188	0	93	0	281	0	392	195	0	587	0	0	0	0	0	100	660	0	1	761	1629
% App. Total	66.9	0	33.1	0		0	66.8	33.2	0		0	0	0	0		13.1	86.7	0	0.1		
PHF	.825	.000	.802	.000	.867	.000	.867	.871	.000	.923	.000	.000	.000	.000	.000	.833	.878	.000	.250	.885	.934

