

SEH CONSULTING
Traffic Data Collection
TURN MOVEMENT COUNT

TH 51 (Snelling Ave) at Larpenteur Ave
Ref.Pt.: 006.350
data by SEH
TURN MOVEMENT COUNT

File Name : TH-51 at Larpenteur Ave 2008
Site Code : 00000016
Start Date : 12/2/2008
Page No : 1

Groups Printed- Unshifted - Heavy Veh

Start Time	TH-51 / Snelling Ave. Southbound				Larpenteur Ave Westbound				TH-51 / Snelling Ave. Northbound				Larpenteur Ave Eastbound				Int. Total
	Left	Thru	Right	Peds	Left	Thru	Right	Peds	Left	Thru	Right	Peds	Left	Thru	Right	Peds	
06:00	4	91	9	0	11	35	4	1	9	74	3	0	2	6	26	0	275
06:15	3	148	7	0	16	61	4	1	14	61	6	0	0	6	29	0	356
06:30	4	165	8	1	35	59	13	2	26	95	3	2	7	15	39	0	474
06:45	9	268	22	3	21	85	5	0	22	120	5	0	2	11	22	2	597
Total	20	672	46	4	83	240	26	4	71	350	17	2	11	38	116	2	1702
07:00	11	262	17	0	37	120	3	1	17	137	5	3	4	29	31	0	677
07:15	7	302	18	2	49	153	16	0	30	156	3	0	6	20	49	1	812
07:30	10	417	26	1	55	180	14	1	35	211	10	0	9	22	61	1	1053
07:45	7	359	29	1	55	195	16	1	57	236	5	0	8	48	49	1	1067
Total	35	1340	90	4	196	648	49	3	139	740	23	3	27	119	190	3	3609
08:00	11	331	17	0	55	142	10	0	48	207	4	0	9	44	39	2	919
08:15	12	282	20	0	61	190	10	3	46	212	7	0	7	28	58	1	937
08:30	10	291	24	0	45	130	13	2	32	206	7	3	15	22	34	1	835
08:45	14	247	20	2	53	140	12	0	46	186	4	1	10	42	64	1	842
Total	47	1151	81	2	214	602	45	5	172	811	22	4	41	136	195	5	3533
*** BREAK ***																	
11:00	20	134	11	0	26	42	22	0	22	211	17	2	21	42	38	0	608
11:15	14	188	11	2	30	52	33	0	35	195	16	3	32	65	30	1	707
11:30	16	189	18	2	34	55	33	0	20	258	23	3	36	47	42	2	778
11:45	26	224	25	3	32	66	28	2	35	281	14	5	37	62	37	1	878
Total	76	735	65	7	122	215	116	2	112	945	70	13	126	216	147	4	2971
12:00	23	216	21	3	39	64	24	0	34	295	17	1	32	55	40	5	869
12:15	34	223	22	3	36	73	24	0	27	258	27	1	30	54	45	0	857
12:30	14	253	20	0	45	68	30	0	36	260	32	3	29	58	36	0	884
12:45	22	247	28	1	38	79	27	1	30	218	20	3	31	40	45	1	831
Total	93	939	91	7	158	284	105	1	127	1031	96	8	122	207	166	6	3441
*** BREAK ***																	
15:00	14	204	19	1	28	62	24	0	42	302	33	1	29	75	42	1	877
15:15	40	235	17	1	24	85	34	0	21	321	32	0	35	95	45	3	988
15:30	23	220	14	5	27	54	20	0	38	395	41	2	25	105	57	2	1028
15:45	26	260	15	0	41	71	32	0	44	336	41	4	52	110	50	1	1083
Total	103	919	65	7	120	272	110	0	145	1354	147	7	141	385	194	7	3976
16:00	14	241	10	3	24	82	24	0	42	390	53	2	37	123	42	0	1087
16:15	19	220	26	0	36	59	37	0	53	375	55	5	48	141	51	1	1126
16:30	32	305	17	2	24	55	31	2	36	444	31	12	38	140	29	3	1201
16:45	40	247	12	2	28	74	27	0	63	445	38	7	47	166	51	2	1249
Total	105	1013	65	7	112	270	119	2	194	1654	177	26	170	570	173	6	4663
17:00	29	297	17	1	24	87	38	0	32	384	31	6	32	144	36	0	1158
17:15	17	282	24	1	22	75	22	0	57	407	44	3	64	167	44	0	1229
17:30	30	302	19	2	29	81	33	0	41	345	41	3	30	175	46	6	1183
17:45	31	261	22	5	36	63	33	0	34	371	27	4	50	116	41	1	1095
Total	107	1142	82	9	111	306	126	0	164	1507	143	16	176	602	167	7	4665
Grand Total	586	7911	585	47	1116	2837	696	17	1124	8392	695	79	814	2273	1348	40	28560
Apprch %	6.4	86.7	6.4	0.5	23.9	60.8	14.9	0.4	10.9	81.6	6.8	0.8	18.2	50.8	30.1	0.9	
Total %	2.1	27.7	2	0.2	3.9	9.9	2.4	0.1	3.9	29.4	2.4	0.3	2.9	8	4.7	0.1	
Unshifted	580	7802	582	47	1105	2809	691	17	1106	8315	688	79	812	2243	1317	40	28233
% Unshifted	99	98.6	99.5	100	99	99	99.3	100	98.4	99.1	99	100	99.8	98.7	97.7	100	98.9
Heavy Veh	6	109	3	0	11	28	5	0	18	77	7	0	2	30	31	0	327
% Heavy Veh	1	1.4	0.5	0	1	1	0.7	0	1.6	0.9	1	0	0.2	1.3	2.3	0	1.1

SEH CONSULTING
Traffic Data Collection
TURN MOVEMENT COUNT

TH 51 (Snelling Ave) at Larpenteur Ave
Ref.Pt.: 006.350
data by SEH
TURN MOVEMENT COUNT

File Name : TH-51 at Larpenteur Ave 2008
Site Code : 00000016
Start Date : 12/2/2008
Page No : 2

Start Time	TH-51 / Snelling Ave. Southbound					Larpenteur Ave Westbound					TH-51 / Snelling Ave. Northbound					Larpenteur Ave Eastbound					Int. Total
	Left	Thru	Right	Peds	App. Total	Left	Thru	Right	Peds	App. Total	Left	Thru	Right	Peds	App. Total	Left	Thru	Right	Peds	App. Total	
Peak Hour Analysis From 06:00 to 08:45 - Peak 1 of 1																					
Peak Hour for Entire Intersection Begins at 07:30																					
07:30	10	417	26	1	454	55	180	14	1	250	35	211	10	0	256	9	22	61	1	93	1053
07:45	7	359	29	1	396	55	195	16	1	267	57	236	5	0	298	8	48	49	1	106	1067
08:00	11	331	17	0	359	55	142	10	0	207	48	207	4	0	259	9	44	39	2	94	919
08:15	12	282	20	0	314	61	190	10	3	264	46	212	7	0	265	7	28	58	1	94	937
Total Volume	40	1389	92	2	1523	226	707	50	5	988	186	866	26	0	1078	33	142	207	5	387	3976
% App. Total	2.6	91.2	6	0.1		22.9	71.6	5.1	0.5		17.3	80.3	2.4	0		8.5	36.7	53.5	1.3		
PHF	.833	.833	.793	.500	.839	.926	.906	.781	.417	.925	.816	.917	.650	.000	.904	.917	.740	.848	.625	.913	.932

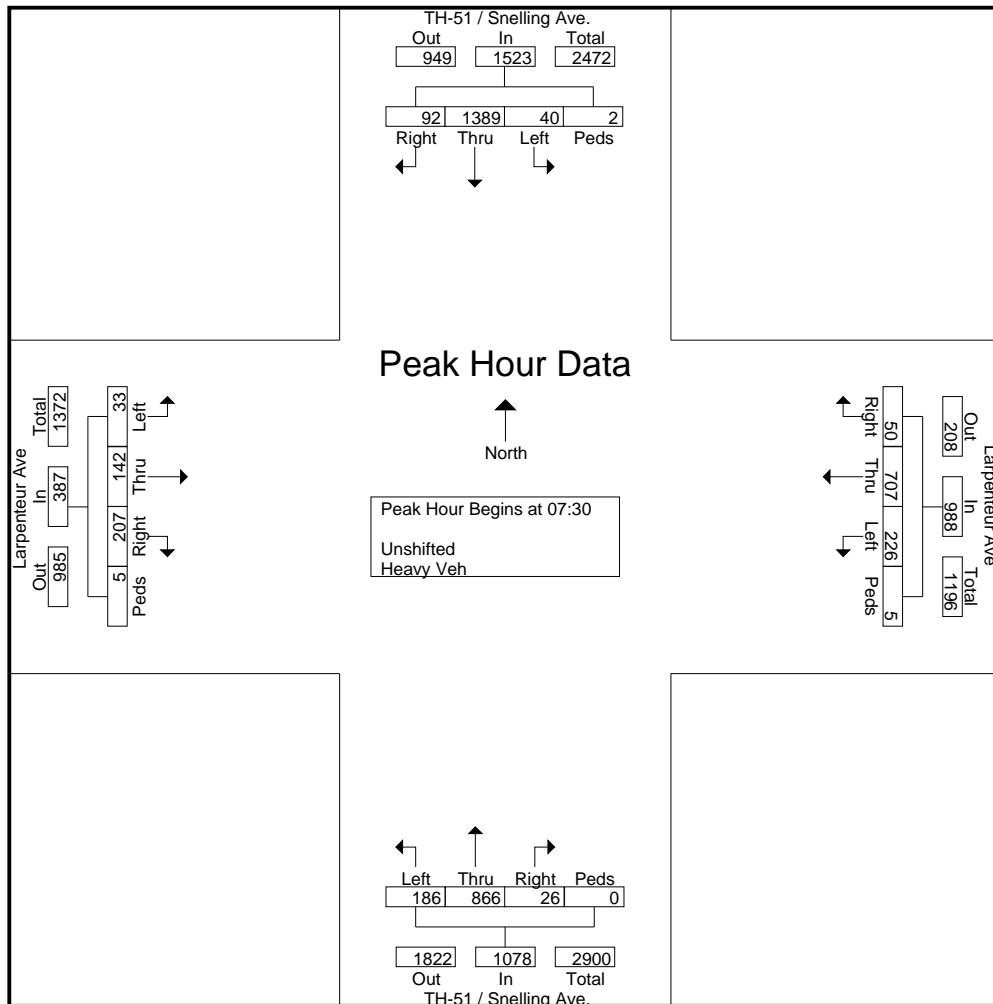

SEH CONSULTING
Traffic Data Collection
TURN MOVEMENT COUNT

TH 51 (Snelling Ave) at Larpenteur Ave
Ref.Pt.: 006.350
data by SEH
TURN MOVEMENT COUNT

File Name : TH-51 at Larpenteur Ave 2008
Site Code : 00000016
Start Date : 12/2/2008
Page No : 3

Start Time	TH-51 / Snelling Ave. Southbound					Larpenteur Ave Westbound					TH-51 / Snelling Ave. Northbound					Larpenteur Ave Eastbound					Int. Total
	Left	Thru	Right	Peds	App. Total	Left	Thru	Right	Peds	App. Total	Left	Thru	Right	Peds	App. Total	Left	Thru	Right	Peds	App. Total	
Peak Hour Analysis From 15:00 to 17:45 - Peak 1 of 1																					
Peak Hour for Entire Intersection Begins at 16:30																					
16:30	32	305	17	2	356	24	55	31	2	112	36	444	31	12	523	38	140	29	3	210	1201
16:45	40	247	12	2	301	28	74	27	0	129	63	445	38	7	553	47	166	51	2	266	1249
17:00	29	297	17	1	344	24	87	38	0	149	32	384	31	6	453	32	144	36	0	212	1158
17:15	17	282	24	1	324	22	75	22	0	119	57	407	44	3	511	64	167	44	0	275	1229
Total Volume	118	1131	70	6	1325	98	291	118	2	509	188	1680	144	28	2040	181	617	160	5	963	4837
% App. Total	8.9	85.4	5.3	0.5		19.3	57.2	23.2	0.4		9.2	82.4	7.1	1.4		18.8	64.1	16.6	0.5		
PHF	.738	.927	.729	.750	.930	.875	.836	.776	.250	.854	.746	.944	.818	.583	.922	.707	.924	.784	.417	.875	.968

