

Associated Consulting Services (ACS)  
 Roseville, MN 55113  
 -- TRAFFIC DATA --

MN-51 at Beechwood Ave\_2022  
 City: St Paul  
 Data Prepared By: ACS  
 TURNING MOVEMENT COUNT

File Name : MN-51 at Beechwood Ave\_2022  
 Site Code :  
 Start Date : 5/3/2022  
 Page No : 1

Groups Printed- Cars - Trucks

| Start Time | MN-51 Southbound |      |       |      | Westbound |      |       |      | MN-51 Northbound |      |       |      | Beechwood Ave Eastbound |      |       |      | Int. Total |     |
|------------|------------------|------|-------|------|-----------|------|-------|------|------------------|------|-------|------|-------------------------|------|-------|------|------------|-----|
|            | Left             | Thru | Right | Peds | Left      | Thru | Right | Peds | Left             | Thru | Right | Peds | Left                    | Thru | Right | Peds |            |     |
| 06:00      | 0                | 24   | 0     | 0    | 0         | 0    | 0     | 0    | 0                | 0    | 39    | 0    | 0                       | 0    | 0     | 0    | 3          | 66  |
| 06:15      | 0                | 42   | 0     | 0    | 0         | 0    | 0     | 0    | 0                | 0    | 28    | 0    | 0                       | 1    | 0     | 1    | 2          | 74  |
| 06:30      | 0                | 46   | 0     | 0    | 0         | 0    | 0     | 0    | 0                | 0    | 44    | 0    | 0                       | 1    | 0     | 0    | 1          | 92  |
| 06:45      | 0                | 53   | 1     | 0    | 0         | 0    | 0     | 0    | 0                | 0    | 53    | 0    | 0                       | 1    | 0     | 1    | 1          | 110 |
| Total      | 0                | 165  | 1     | 0    | 0         | 0    | 0     | 0    | 0                | 0    | 164   | 0    | 0                       | 3    | 0     | 2    | 7          | 342 |
| 07:00      | 0                | 63   | 0     | 0    | 0         | 0    | 0     | 0    | 0                | 1    | 59    | 0    | 0                       | 0    | 0     | 2    | 0          | 125 |
| 07:15      | 0                | 84   | 3     | 0    | 0         | 0    | 0     | 0    | 0                | 1    | 82    | 0    | 0                       | 2    | 0     | 0    | 1          | 173 |
| 07:30      | 0                | 79   | 1     | 0    | 0         | 0    | 0     | 0    | 0                | 0    | 81    | 0    | 0                       | 2    | 0     | 1    | 1          | 165 |
| 07:45      | 0                | 104  | 0     | 0    | 0         | 0    | 0     | 0    | 0                | 1    | 102   | 0    | 0                       | 2    | 0     | 2    | 5          | 216 |
| Total      | 0                | 330  | 4     | 0    | 0         | 0    | 0     | 0    | 0                | 3    | 324   | 0    | 0                       | 6    | 0     | 5    | 7          | 679 |
| 08:00      | 0                | 101  | 0     | 0    | 0         | 0    | 0     | 0    | 0                | 1    | 108   | 0    | 0                       | 0    | 0     | 3    | 7          | 220 |
| 08:15      | 0                | 165  | 2     | 0    | 0         | 0    | 0     | 0    | 0                | 2    | 114   | 0    | 0                       | 1    | 0     | 4    | 9          | 297 |
| 08:30      | 0                | 89   | 1     | 0    | 0         | 0    | 0     | 0    | 0                | 2    | 110   | 0    | 0                       | 5    | 0     | 2    | 2          | 211 |
| 08:45      | 0                | 76   | 2     | 0    | 0         | 0    | 0     | 0    | 0                | 0    | 77    | 0    | 0                       | 1    | 0     | 1    | 5          | 162 |
| Total      | 0                | 431  | 5     | 0    | 0         | 0    | 0     | 0    | 0                | 5    | 409   | 0    | 0                       | 7    | 0     | 10   | 23         | 890 |
| 09:00      | 0                | 79   | 0     | 0    | 0         | 0    | 0     | 0    | 0                | 0    | 67    | 0    | 0                       | 1    | 0     | 1    | 0          | 148 |
| 09:15      | 0                | 77   | 1     | 0    | 0         | 0    | 0     | 0    | 0                | 0    | 101   | 0    | 0                       | 1    | 0     | 0    | 0          | 180 |
| 09:30      | 0                | 67   | 0     | 0    | 0         | 0    | 0     | 0    | 0                | 0    | 94    | 0    | 0                       | 1    | 0     | 1    | 2          | 165 |
| 09:45      | 0                | 73   | 3     | 0    | 0         | 0    | 0     | 0    | 0                | 1    | 64    | 0    | 0                       | 1    | 0     | 2    | 4          | 148 |
| Total      | 0                | 296  | 4     | 0    | 0         | 0    | 0     | 0    | 0                | 1    | 326   | 0    | 0                       | 4    | 0     | 4    | 6          | 641 |
| 10:00      | 0                | 69   | 0     | 0    | 0         | 0    | 0     | 0    | 0                | 2    | 77    | 0    | 0                       | 0    | 0     | 1    | 1          | 150 |
| 10:15      | 0                | 73   | 1     | 0    | 0         | 0    | 0     | 0    | 0                | 1    | 64    | 0    | 0                       | 2    | 0     | 1    | 1          | 143 |
| 10:30      | 0                | 86   | 0     | 0    | 0         | 0    | 0     | 0    | 0                | 0    | 64    | 0    | 0                       | 0    | 0     | 1    | 0          | 151 |
| 10:45      | 0                | 84   | 1     | 0    | 0         | 0    | 0     | 0    | 0                | 1    | 69    | 0    | 0                       | 1    | 0     | 1    | 0          | 157 |
| Total      | 0                | 312  | 2     | 0    | 0         | 0    | 0     | 0    | 0                | 4    | 274   | 0    | 0                       | 3    | 0     | 4    | 2          | 601 |
| 11:00      | 0                | 67   | 1     | 0    | 0         | 0    | 0     | 0    | 0                | 0    | 72    | 0    | 0                       | 0    | 0     | 0    | 1          | 141 |
| 11:15      | 0                | 77   | 0     | 0    | 0         | 0    | 0     | 0    | 0                | 1    | 81    | 0    | 0                       | 1    | 0     | 1    | 2          | 163 |
| 11:30      | 0                | 75   | 0     | 0    | 0         | 0    | 0     | 0    | 0                | 2    | 80    | 0    | 0                       | 1    | 0     | 0    | 1          | 159 |
| 11:45      | 0                | 82   | 1     | 0    | 0         | 0    | 0     | 0    | 0                | 2    | 72    | 0    | 0                       | 0    | 0     | 0    | 4          | 161 |
| Total      | 0                | 301  | 2     | 0    | 0         | 0    | 0     | 0    | 0                | 5    | 305   | 0    | 0                       | 2    | 0     | 1    | 8          | 624 |
| 12:00      | 0                | 81   | 3     | 0    | 0         | 0    | 0     | 0    | 0                | 0    | 80    | 0    | 0                       | 1    | 0     | 1    | 6          | 172 |
| 12:15      | 0                | 86   | 1     | 0    | 0         | 0    | 0     | 0    | 0                | 0    | 75    | 0    | 0                       | 0    | 0     | 3    | 7          | 172 |
| 12:30      | 0                | 102  | 0     | 0    | 0         | 0    | 0     | 0    | 0                | 1    | 84    | 0    | 0                       | 3    | 0     | 2    | 1          | 193 |
| 12:45      | 0                | 73   | 0     | 0    | 0         | 0    | 0     | 0    | 0                | 1    | 69    | 0    | 2                       | 0    | 0     | 1    | 3          | 149 |
| Total      | 0                | 342  | 4     | 0    | 0         | 0    | 0     | 0    | 0                | 2    | 308   | 0    | 2                       | 4    | 0     | 7    | 17         | 686 |
| 13:00      | 0                | 84   | 1     | 0    | 0         | 0    | 0     | 0    | 0                | 0    | 86    | 0    | 0                       | 0    | 0     | 1    | 0          | 172 |
| 13:15      | 0                | 90   | 1     | 0    | 0         | 0    | 0     | 0    | 0                | 1    | 83    | 0    | 0                       | 0    | 0     | 0    | 3          | 178 |
| 13:30      | 0                | 90   | 2     | 0    | 0         | 0    | 0     | 0    | 0                | 0    | 77    | 0    | 0                       | 1    | 0     | 1    | 3          | 174 |
| 13:45      | 0                | 87   | 0     | 0    | 0         | 0    | 0     | 0    | 0                | 1    | 101   | 0    | 0                       | 0    | 0     | 1    | 1          | 191 |
| Total      | 0                | 351  | 4     | 0    | 0         | 0    | 0     | 0    | 0                | 2    | 347   | 0    | 0                       | 1    | 0     | 3    | 7          | 715 |
| 14:00      | 0                | 90   | 1     | 0    | 0         | 0    | 0     | 0    | 0                | 0    | 81    | 0    | 0                       | 0    | 0     | 2    | 3          | 177 |
| 14:15      | 0                | 100  | 0     | 0    | 0         | 0    | 0     | 0    | 0                | 0    | 91    | 0    | 0                       | 0    | 0     | 1    | 4          | 196 |
| 14:30      | 0                | 98   | 3     | 0    | 0         | 0    | 0     | 0    | 0                | 0    | 98    | 0    | 0                       | 0    | 0     | 1    | 3          | 203 |
| 14:45      | 0                | 136  | 2     | 0    | 0         | 0    | 0     | 0    | 0                | 2    | 104   | 0    | 0                       | 0    | 0     | 0    | 3          | 247 |
| Total      | 0                | 424  | 6     | 0    | 0         | 0    | 0     | 0    | 0                | 2    | 374   | 0    | 0                       | 0    | 0     | 4    | 13         | 823 |

Associated Consulting Services (ACS)  
 Roseville, MN 55113  
 -- TRAFFIC DATA --

MN-51 at Beechwood Ave\_2022  
 City: St Paul  
 Data Prepared By: ACS  
 TURNING MOVEMENT COUNT

File Name : MN-51 at Beechwood Ave\_2022  
 Site Code :  
 Start Date : 5/3/2022  
 Page No : 2

Groups Printed- Cars - Trucks

| Start Time  | MN-51 Southbound |      |       |      | Westbound |      |       |      | MN-51 Northbound |      |       |      | Beechwood Ave Eastbound |      |       |      | Int. Total |
|-------------|------------------|------|-------|------|-----------|------|-------|------|------------------|------|-------|------|-------------------------|------|-------|------|------------|
|             | Left             | Thru | Right | Peds | Left      | Thru | Right | Peds | Left             | Thru | Right | Peds | Left                    | Thru | Right | Peds |            |
| 15:00       | 0                | 150  | 3     | 0    | 0         | 0    | 0     | 0    | 1                | 127  | 0     | 0    | 0                       | 0    | 3     | 34   | 318        |
| 15:15       | 0                | 145  | 2     | 0    | 0         | 0    | 0     | 0    | 1                | 135  | 0     | 2    | 3                       | 0    | 0     | 9    | 297        |
| 15:30       | 0                | 127  | 2     | 0    | 0         | 0    | 0     | 0    | 0                | 108  | 0     | 0    | 0                       | 0    | 0     | 4    | 241        |
| 15:45       | 0                | 111  | 2     | 0    | 0         | 0    | 0     | 0    | 0                | 106  | 0     | 0    | 0                       | 0    | 0     | 14   | 233        |
| Total       | 0                | 533  | 9     | 0    | 0         | 0    | 0     | 0    | 2                | 476  | 0     | 2    | 3                       | 0    | 3     | 61   | 1089       |
| 16:00       | 0                | 137  | 1     | 0    | 0         | 0    | 0     | 0    | 3                | 125  | 0     | 1    | 1                       | 0    | 2     | 8    | 278        |
| 16:15       | 0                | 108  | 1     | 0    | 0         | 0    | 0     | 0    | 0                | 117  | 0     | 0    | 1                       | 0    | 2     | 3    | 232        |
| 16:30       | 0                | 119  | 7     | 0    | 0         | 0    | 0     | 0    | 3                | 137  | 0     | 0    | 1                       | 0    | 1     | 0    | 268        |
| 16:45       | 0                | 136  | 0     | 0    | 0         | 0    | 0     | 0    | 2                | 127  | 0     | 1    | 1                       | 0    | 0     | 6    | 273        |
| Total       | 0                | 500  | 9     | 0    | 0         | 0    | 0     | 0    | 8                | 506  | 0     | 2    | 4                       | 0    | 5     | 17   | 1051       |
| 17:00       | 0                | 129  | 2     | 0    | 0         | 0    | 0     | 0    | 2                | 133  | 0     | 0    | 0                       | 0    | 3     | 13   | 282        |
| 17:15       | 0                | 125  | 0     | 0    | 0         | 0    | 0     | 0    | 1                | 129  | 0     | 0    | 0                       | 0    | 0     | 4    | 259        |
| 17:30       | 0                | 125  | 5     | 0    | 0         | 0    | 0     | 0    | 1                | 134  | 0     | 0    | 0                       | 0    | 1     | 2    | 268        |
| 17:45       | 0                | 124  | 0     | 0    | 0         | 0    | 0     | 0    | 1                | 102  | 0     | 0    | 0                       | 0    | 0     | 5    | 232        |
| Total       | 0                | 503  | 7     | 0    | 0         | 0    | 0     | 0    | 5                | 498  | 0     | 0    | 0                       | 0    | 4     | 24   | 1041       |
| Grand Total | 0                | 4488 | 57    | 0    | 0         | 0    | 0     | 0    | 39               | 4311 | 0     | 6    | 37                      | 0    | 52    | 192  | 9182       |
| Apprch %    | 0                | 98.7 | 1.3   | 0    | 0         | 0    | 0     | 0    | 0.9              | 99   | 0     | 0.1  | 13.2                    | 0    | 18.5  | 68.3 |            |
| Total %     | 0                | 48.9 | 0.6   | 0    | 0         | 0    | 0     | 0    | 0.4              | 47   | 0     | 0.1  | 0.4                     | 0    | 0.6   | 2.1  |            |
| Cars        | 0                | 4190 | 54    | 0    | 0         | 0    | 0     | 0    | 37               | 4042 | 0     | 6    | 37                      | 0    | 51    | 192  | 8609       |
| % Cars      | 0                | 93.4 | 94.7  | 0    | 0         | 0    | 0     | 0    | 94.9             | 93.8 | 0     | 100  | 100                     | 0    | 98.1  | 100  | 93.8       |
| Trucks      | 0                | 298  | 3     | 0    | 0         | 0    | 0     | 0    | 2                | 269  | 0     | 0    | 0                       | 0    | 1     | 0    | 573        |
| % Trucks    | 0                | 6.6  | 5.3   | 0    | 0         | 0    | 0     | 0    | 5.1              | 6.2  | 0     | 0    | 0                       | 0    | 1.9   | 0    | 6.2        |

Associated Consulting Services (ACS)  
 Roseville, MN 55113  
 -- TRAFFIC DATA --

MN-51 at Beechwood Ave\_2022  
 City: St Paul  
 Data Prepared By: ACS  
 TURNING MOVEMENT COUNT

File Name : MN-51 at Beechwood Ave\_2022  
 Site Code :  
 Start Date : 5/3/2022  
 Page No : 3

| Start Time   | MN-51 Southbound |      |       |      |            | Westbound |      |       |      |            | MN-51 Northbound |      |       |      |            | Beechwood Ave Eastbound |      |       |      |            | Int. Total |
|--|------------------|------|-------|------|------------|-----------|------|-------|------|------------|------------------|------|-------|------|------------|-------------------------|------|-------|------|------------|------------|
|  | Left             | Thru | Right | Peds | App. Total | Left      | Thru | Right | Peds | App. Total | Left             | Thru | Right | Peds | App. Total | Left                    | Thru | Right | Peds | App. Total |            |
| Peak Hour Analysis From 06:00 to 11:45 - Peak 1 of 1 |                  |      |       |      |            |           |      |       |      |            |                  |      |       |      |            |                         |      |       |      |            |            |
| Peak Hour for Entire Intersection Begins at 07:45    |                  |      |       |      |            |           |      |       |      |            |                  |      |       |      |            |                         |      |       |      |            |            |
| 07:45  | 0                | 104  | 0     | 0    | 104        | 0         | 0    | 0     | 0    | 0          | 1                | 102  | 0     | 0    | 103        | 2                       | 0    | 2     | 5    | 9          | 216        |
| 08:00  | 0                | 101  | 0     | 0    | 101        | 0         | 0    | 0     | 0    | 0          | 1                | 108  | 0     | 0    | 109        | 0                       | 0    | 3     | 7    | 10         | 220        |
| 08:15  | 0                | 165  | 2     | 0    | 167        | 0         | 0    | 0     | 0    | 0          | 2                | 114  | 0     | 0    | 116        | 1                       | 0    | 4     | 9    | 14         | 297        |
| 08:30  | 0                | 89   | 1     | 0    | 90         | 0         | 0    | 0     | 0    | 0          | 2                | 110  | 0     | 0    | 112        | 5                       | 0    | 2     | 2    | 9          | 211        |
| Total Volume   | 0                | 459  | 3     | 0    | 462        | 0         | 0    | 0     | 0    | 0          | 6                | 434  | 0     | 0    | 440        | 8                       | 0    | 11    | 23   | 42         | 944        |
| % App. Total   | 0                | 99.4 | 0.6   | 0    |            | 0         | 0    | 0     | 0    |            | 1.4              | 98.6 | 0     | 0    |            | 19                      | 0    | 26.2  | 54.8 |            |            |
| PHF  | .000             | .695 | .375  | .000 | .692       | .000      | .000 | .000  | .000 | .000       | .750             | .952 | .000  | .000 | .948       | .400                    | .000 | .688  | .639 | .750       | .795       |

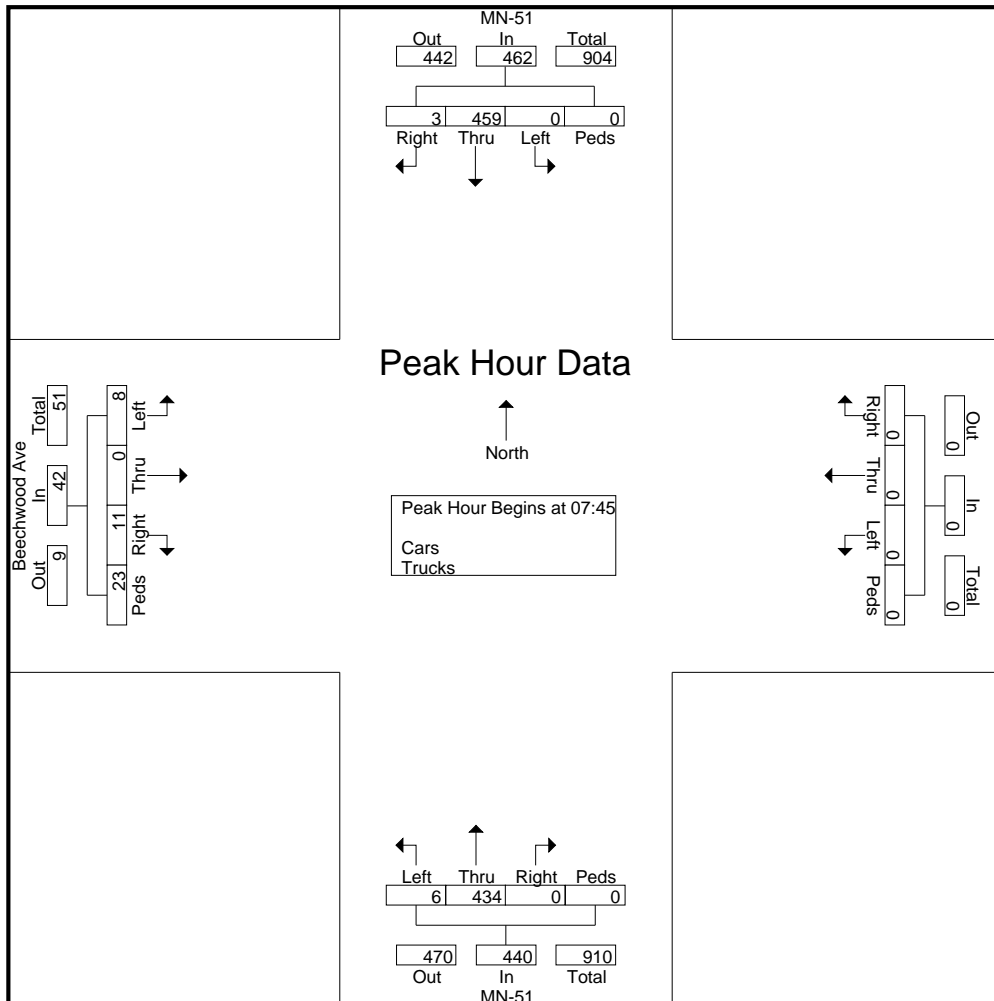

Associated Consulting Services (ACS)  
 Roseville, MN 55113  
 -- TRAFFIC DATA --

MN-51 at Beechwood Ave\_2022  
 City: St Paul  
 Data Prepared By: ACS  
 TURNING MOVEMENT COUNT

File Name : MN-51 at Beechwood Ave\_2022  
 Site Code :  
 Start Date : 5/3/2022  
 Page No : 4

| Start Time   | MN-51 Southbound |      |       |      |            | Westbound |      |       |      |            | MN-51 Northbound |      |       |      |            | Beechwood Ave Eastbound |      |       |      |            | Int. Total |
|--|------------------|------|-------|------|------------|-----------|------|-------|------|------------|------------------|------|-------|------|------------|-------------------------|------|-------|------|------------|------------|
|  | Left             | Thru | Right | Peds | App. Total | Left      | Thru | Right | Peds | App. Total | Left             | Thru | Right | Peds | App. Total | Left                    | Thru | Right | Peds | App. Total |            |
| Peak Hour Analysis From 12:00 to 17:45 - Peak 1 of 1 |                  |      |       |      |            |           |      |       |      |            |                  |      |       |      |            |                         |      |       |      |            |            |
| Peak Hour for Entire Intersection Begins at 14:45    |                  |      |       |      |            |           |      |       |      |            |                  |      |       |      |            |                         |      |       |      |            |            |
| 14:45  | 0                | 136  | 2     | 0    | 138        | 0         | 0    | 0     | 0    | 0          | 2                | 104  | 0     | 0    | 106        | 0                       | 0    | 0     | 3    | 3          | 247        |
| 15:00  | 0                | 150  | 3     | 0    | 153        | 0         | 0    | 0     | 0    | 0          | 1                | 127  | 0     | 0    | 128        | 0                       | 0    | 3     | 34   | 37         | 318        |
| 15:15  | 0                | 145  | 2     | 0    | 147        | 0         | 0    | 0     | 0    | 0          | 1                | 135  | 0     | 2    | 138        | 3                       | 0    | 0     | 9    | 12         | 297        |
| 15:30  | 0                | 127  | 2     | 0    | 129        | 0         | 0    | 0     | 0    | 0          | 0                | 108  | 0     | 0    | 108        | 0                       | 0    | 0     | 4    | 4          | 241        |
| Total Volume   | 0                | 558  | 9     | 0    | 567        | 0         | 0    | 0     | 0    | 0          | 4                | 474  | 0     | 2    | 480        | 3                       | 0    | 3     | 50   | 56         | 1103       |
| % App. Total   | 0                | 98.4 | 1.6   | 0    |            | 0         | 0    | 0     | 0    |            | 0.8              | 98.8 | 0     | 0.4  |            | 5.4                     | 0    | 5.4   | 89.3 |            |            |
| PHF  | .000             | .930 | .750  | .000 | .926       | .000      | .000 | .000  | .000 | .000       | .500             | .878 | .000  | .250 | .870       | .250                    | .000 | .250  | .368 | .378       | .867       |

