



701 Xenia Ave S, Suite 300  
 Minneapolis, MN 55416

River  
 7-9am & 4-6pm  
 vehicles, heavy trucks, peds, bikes  
 day two

File Name : site 1-River day two  
 Site Code : 1  
 Start Date : 3/21/2022  
 Page No : 1

Groups Printed- vehicles & peds - heavy trucks & bikes

| Start Time             | River From North |      |      |       |            | From East |      |      |       |            | River From South |      |      |       |            | From West |      |      |       |            | Int. Total |       |
|------------------------|------------------|------|------|-------|------------|-----------|------|------|-------|------------|------------------|------|------|-------|------------|-----------|------|------|-------|------------|------------|-------|
|                        | Right            | Thru | Left | bikes | App. Total | Right     | Thru | Left | bikes | App. Total | Right            | Thru | Left | bikes | App. Total | Right     | Thru | Left | bikes | App. Total |            |       |
| 07:00 AM               | 0                | 316  | 0    | 0     | 316        | 0         | 0    | 0    | 0     | 0          | 0                | 226  | 0    | 0     | 226        | 0         | 0    | 0    | 0     | 0          | 0          | 542   |
| 07:15 AM               | 0                | 428  | 0    | 0     | 428        | 0         | 0    | 0    | 0     | 0          | 0                | 281  | 0    | 0     | 281        | 0         | 0    | 0    | 0     | 0          | 0          | 709   |
| 07:30 AM               | 0                | 483  | 0    | 0     | 483        | 0         | 0    | 0    | 0     | 0          | 0                | 381  | 0    | 0     | 381        | 0         | 0    | 0    | 0     | 0          | 0          | 864   |
| 07:45 AM               | 0                | 465  | 0    | 0     | 465        | 0         | 0    | 0    | 0     | 0          | 0                | 452  | 0    | 0     | 452        | 0         | 0    | 0    | 0     | 0          | 0          | 917   |
| Total                  | 0                | 1692 | 0    | 0     | 1692       | 0         | 0    | 0    | 0     | 0          | 0                | 1340 | 0    | 0     | 1340       | 0         | 0    | 0    | 0     | 0          | 0          | 3032  |
| 08:00 AM               | 0                | 405  | 0    | 0     | 405        | 0         | 0    | 0    | 0     | 0          | 0                | 347  | 0    | 0     | 347        | 0         | 0    | 0    | 0     | 0          | 0          | 752   |
| 08:15 AM               | 0                | 404  | 0    | 0     | 404        | 0         | 0    | 0    | 0     | 0          | 0                | 361  | 0    | 0     | 361        | 0         | 0    | 0    | 2     | 2          | 2          | 767   |
| 08:30 AM               | 0                | 398  | 0    | 0     | 398        | 0         | 0    | 0    | 0     | 0          | 0                | 378  | 0    | 0     | 378        | 0         | 0    | 0    | 0     | 0          | 0          | 776   |
| 08:45 AM               | 0                | 341  | 0    | 0     | 341        | 0         | 0    | 0    | 0     | 0          | 0                | 336  | 0    | 0     | 336        | 0         | 0    | 0    | 0     | 0          | 0          | 677   |
| Total                  | 0                | 1548 | 0    | 0     | 1548       | 0         | 0    | 0    | 0     | 0          | 0                | 1422 | 0    | 0     | 1422       | 0         | 0    | 0    | 2     | 2          | 2          | 2972  |
| 04:00 PM               | 0                | 440  | 0    | 0     | 440        | 0         | 0    | 0    | 0     | 0          | 0                | 471  | 0    | 0     | 471        | 0         | 0    | 0    | 0     | 0          | 0          | 911   |
| 04:15 PM               | 0                | 475  | 0    | 0     | 475        | 0         | 0    | 0    | 0     | 0          | 0                | 473  | 0    | 0     | 473        | 0         | 0    | 0    | 1     | 1          | 1          | 949   |
| 04:30 PM               | 0                | 472  | 0    | 0     | 472        | 0         | 0    | 0    | 0     | 0          | 0                | 528  | 0    | 0     | 528        | 0         | 0    | 0    | 4     | 4          | 4          | 1004  |
| 04:45 PM               | 0                | 469  | 0    | 0     | 469        | 0         | 0    | 0    | 0     | 0          | 0                | 520  | 0    | 0     | 520        | 0         | 0    | 0    | 0     | 0          | 0          | 989   |
| Total                  | 0                | 1856 | 0    | 0     | 1856       | 0         | 0    | 0    | 0     | 0          | 0                | 1992 | 0    | 0     | 1992       | 0         | 0    | 0    | 5     | 5          | 5          | 3853  |
| 05:00 PM               | 0                | 444  | 0    | 0     | 444        | 0         | 0    | 0    | 0     | 0          | 0                | 599  | 0    | 0     | 599        | 0         | 0    | 0    | 7     | 7          | 7          | 1050  |
| 05:15 PM               | 0                | 454  | 0    | 0     | 454        | 0         | 0    | 0    | 0     | 0          | 0                | 596  | 0    | 0     | 596        | 0         | 0    | 0    | 8     | 8          | 8          | 1058  |
| 05:30 PM               | 0                | 387  | 0    | 0     | 387        | 0         | 0    | 0    | 0     | 0          | 0                | 529  | 0    | 0     | 529        | 0         | 0    | 0    | 10    | 10         | 10         | 926   |
| 05:45 PM               | 0                | 377  | 0    | 0     | 377        | 0         | 0    | 0    | 0     | 0          | 0                | 531  | 0    | 0     | 531        | 0         | 0    | 0    | 5     | 5          | 5          | 913   |
| Total                  | 0                | 1662 | 0    | 0     | 1662       | 0         | 0    | 0    | 0     | 0          | 0                | 2255 | 0    | 0     | 2255       | 0         | 0    | 0    | 30    | 30         | 30         | 3947  |
| Grand Total            | 0                | 6758 | 0    | 0     | 6758       | 0         | 0    | 0    | 0     | 0          | 0                | 7009 | 0    | 0     | 7009       | 0         | 0    | 0    | 37    | 37         | 37         | 13804 |
| Apprch %               | 0                | 100  | 0    | 0     |            | 0         | 0    | 0    | 0     |            | 0                | 100  | 0    | 0     |            | 0         | 0    | 0    | 100   |            |            |       |
| Total %                | 0                | 49   | 0    | 0     | 49         | 0         | 0    | 0    | 0     | 0          | 0                | 50.8 | 0    | 0     | 50.8       | 0         | 0    | 0    | 0.3   | 0.3        |            |       |
| vehicles & peds        | 0                | 6687 | 0    | 0     | 6687       | 0         | 0    | 0    | 0     | 0          | 0                | 6964 | 0    | 0     | 6964       | 0         | 0    | 0    | 18    | 18         | 18         | 13669 |
| % vehicles & peds      | 0                | 98.9 | 0    | 0     | 98.9       | 0         | 0    | 0    | 0     | 0          | 0                | 99.4 | 0    | 0     | 99.4       | 0         | 0    | 0    | 48.6  | 48.6       | 48.6       | 99    |
| heavy trucks & bikes   | 0                | 71   | 0    | 0     | 71         | 0         | 0    | 0    | 0     | 0          | 0                | 45   | 0    | 0     | 45         | 0         | 0    | 0    | 19    | 19         | 19         | 135   |
| % heavy trucks & bikes | 0                | 1.1  | 0    | 0     | 1.1        | 0         | 0    | 0    | 0     | 0          | 0                | 0.6  | 0    | 0     | 0.6        | 0         | 0    | 0    | 51.4  | 51.4       | 51.4       | 1     |

River  
 7-9am & 4-6pm  
 vehicles, heavy trucks, peds, bikes  
 day two

File Name : site 1-River day two  
 Site Code : 1  
 Start Date : 3/21/2022  
 Page No : 2

| Start Time   | River From North |       |      |        |            | From East |       |      |        |            | River From South |       |      |        |            | From West |       |      |        |            | Int. Total |
|--|------------------|-------|------|--------|------------|-----------|-------|------|--------|------------|------------------|-------|------|--------|------------|-----------|-------|------|--------|------------|------------|
|  | Rig ht           | Thr u | Left | bike s | App. Total | Rig ht    | Thr u | Left | bike s | App. Total | Rig ht           | Thr u | Left | bike s | App. Total | Rig ht    | Thr u | Left | bike s | App. Total |            |
| Peak Hour Analysis From 07:00 AM to 11:45 AM - Peak 1 of 1 |                  |       |      |        |            |           |       |      |        |            |                  |       |      |        |            |           |       |      |        |            |            |
| Peak Hour for Entire Intersection Begins at 07:30 AM       |                  |       |      |        |            |           |       |      |        |            |                  |       |      |        |            |           |       |      |        |            |            |
| 07:30 AM   | 0                | 483   | 0    | 0      | 483        | 0         | 0     | 0    | 0      | 0          | 0                | 381   | 0    | 0      | 381        | 0         | 0     | 0    | 0      | 0          | 864        |
| 07:45 AM   | 0                | 465   | 0    | 0      | 465        | 0         | 0     | 0    | 0      | 0          | 0                | 452   | 0    | 0      | 452        | 0         | 0     | 0    | 0      | 0          | 917        |
| 08:00 AM   | 0                | 405   | 0    | 0      | 405        | 0         | 0     | 0    | 0      | 0          | 0                | 347   | 0    | 0      | 347        | 0         | 0     | 0    | 0      | 0          | 752        |
| 08:15 AM   | 0                | 404   | 0    | 0      | 404        | 0         | 0     | 0    | 0      | 0          | 0                | 361   | 0    | 0      | 361        | 0         | 0     | 0    | 2      | 2          | 767        |
| Total Volume   | 0                | 1757  | 0    | 0      | 1757       | 0         | 0     | 0    | 0      | 0          | 0                | 1541  | 0    | 0      | 1541       | 0         | 0     | 0    | 2      | 2          | 3300       |
| % App. Total   | 0                | 100   | 0    | 0      |            | 0         | 0     | 0    | 0      | 0          | 0                | 100   | 0    | 0      |            | 0         | 0     | 0    | 100    |            |            |
| PHF  | .000             | .909  | .000 | .000   | .909       | .000      | .000  | .000 | .000   | .000       | .000             | .852  | .000 | .000   | .852       | .000      | .000  | .000 | .250   | .250       | .900       |

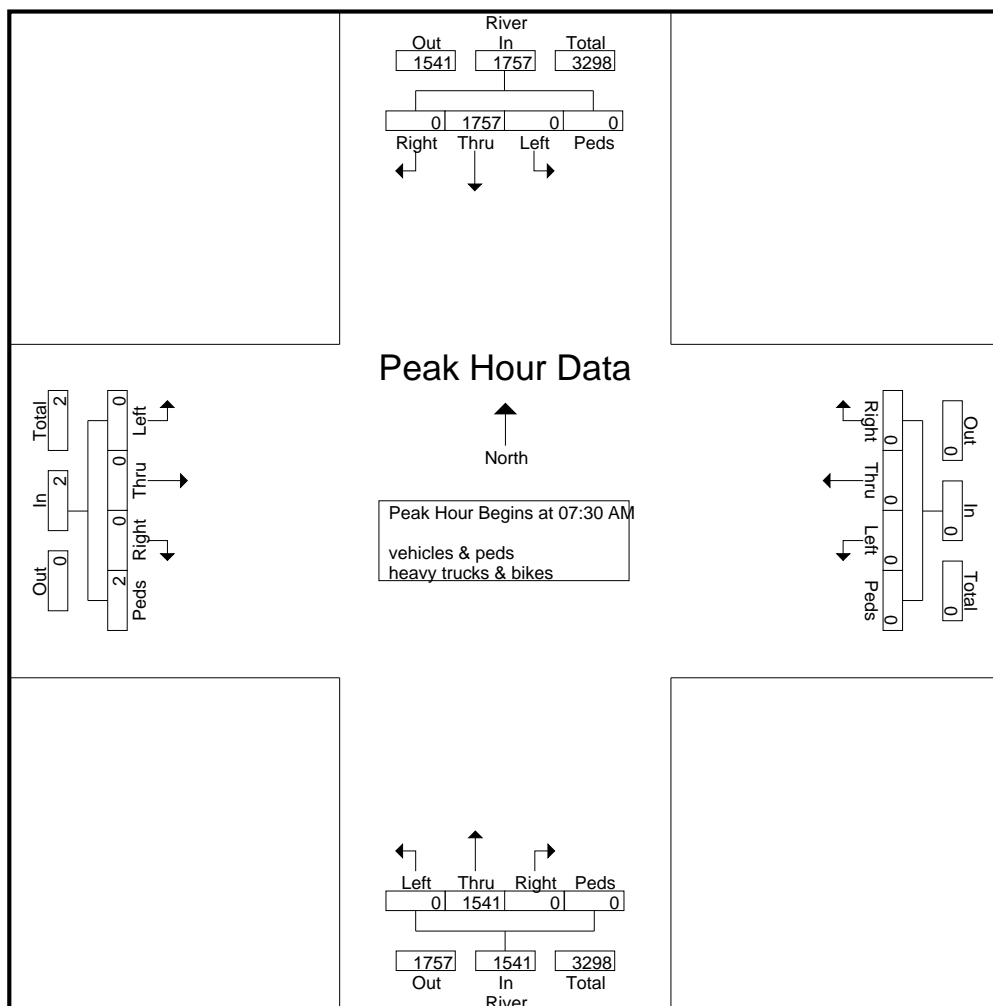

River  
 7-9am & 4-6pm  
 vehicles, heavy trucks, peds, bikes  
 day two

File Name : site 1-River day two  
 Site Code : 1  
 Start Date : 3/21/2022  
 Page No : 3

| Start Time   | River From North |       |      |        |            | From East |       |      |        |            | River From South |       |      |       |            | From West |       |      |       |            | Int. Total |
|--|------------------|-------|------|--------|------------|-----------|-------|------|--------|------------|------------------|-------|------|-------|------------|-----------|-------|------|-------|------------|------------|
|  | Rig ht           | Thr u | Left | bike s | App. Total | Rig ht    | Thr u | Left | bike s | App. Total | Right            | Thr u | Left | bikes | App. Total | Right     | Thr u | Left | bikes | App. Total |            |
| Peak Hour Analysis From 12:00 PM to 05:45 PM - Peak 1 of 1 |                  |       |      |        |            |           |       |      |        |            |                  |       |      |       |            |           |       |      |       |            |            |
| Peak Hour for Entire Intersection Begins at 04:30 PM       |                  |       |      |        |            |           |       |      |        |            |                  |       |      |       |            |           |       |      |       |            |            |
| 04:30 PM   | 0                | 472   | 0    | 0      | 472        | 0         | 0     | 0    | 0      | 0          | 0                | 528   | 0    | 0     | 528        | 0         | 0     | 0    | 4     | 4          | 1004       |
| 04:45 PM   | 0                | 469   | 0    | 0      | 469        | 0         | 0     | 0    | 0      | 0          | 0                | 520   | 0    | 0     | 520        | 0         | 0     | 0    | 0     | 0          | 989        |
| 05:00 PM   | 0                | 444   | 0    | 0      | 444        | 0         | 0     | 0    | 0      | 0          | 0                | 599   | 0    | 0     | 599        | 0         | 0     | 0    | 7     | 7          | 1050       |
| 05:15 PM   | 0                | 454   | 0    | 0      | 454        | 0         | 0     | 0    | 0      | 0          | 0                | 596   | 0    | 0     | 596        | 0         | 0     | 0    | 8     | 8          | 1058       |
| Total Volume   | 0                | 1839  | 0    | 0      | 1839       | 0         | 0     | 0    | 0      | 0          | 0                | 2243  | 0    | 0     | 2243       | 0         | 0     | 0    | 19    | 19         | 4101       |
| % App. Total   | 0                | 100   | 0    | 0      |            | 0         | 0     | 0    | 0      |            | 0                | 100   | 0    | 0     |            | 0         | 0     | 0    | 100   |            |            |
| PHF  | .000             | .974  | .000 | .000   | .974       | .000      | .000  | .000 | .000   | .000       | .000             | .936  | .000 | .000  | .936       | .000      | .000  | .000 | .594  | .594       | .969       |

