



MINNESOTA DEPT OF TRANSPORTATION

TRAFFIC DATA COLLECTION - METRO

TH-5 at Eden Prairie Rd / CSAH-4
 Ref.Pt.: 047.044
 Data by: Westwood Professional Services
 TURN MOVEMENT COUNT

File Name : TH-5 at Eden Prairie Rd CSAH-4 2008
 Site Code : 15052417
 Start Date : 9/17/2008
 Page No : 1

Groups Printed- Unshifted

Start Time	Eden Prairie Rd. / CSAH-4 Southbound				TH-5 Westbound				Eden Prairie Rd. / CSAH-4 Northbound				TH-5 Eastbound				Int. Total
	Left	Thru	Right	Peds	Left	Thru	Right	Peds	Left	Thru	Right	Peds	Left	Thru	Right	Peds	
06:00	37	11	2	0	5	125	2	0	4	17	6	0	8	221	4	0	442
06:15	32	15	5	0	14	164	14	0	8	15	17	0	7	279	3	0	573
06:30	52	19	2	0	20	199	22	0	12	30	34	0	6	359	7	0	762
06:45	70	31	3	0	13	221	31	0	19	48	12	0	8	419	16	0	891
Total	191	76	12	0	52	709	69	0	43	110	69	0	29	1278	30	0	2668
07:00	90	27	8	0	12	191	43	0	22	63	27	0	18	432	6	0	939
07:15	114	43	1	0	15	196	81	0	22	109	29	0	16	485	11	0	1122
07:30	109	66	8	0	19	219	54	0	15	97	48	0	12	534	8	0	1189
07:45	69	67	4	0	20	257	43	0	15	91	69	0	21	529	9	0	1194
Total	382	203	21	0	66	863	221	0	74	360	173	0	67	1980	34	0	4444
08:00	86	50	6	0	13	216	71	0	18	128	69	0	23	471	19	0	1170
08:15	99	70	5	0	21	232	30	0	21	99	48	0	14	385	20	0	1044
08:30	72	53	11	0	17	231	25	0	25	36	34	0	21	359	16	0	900
08:45	75	41	5	0	18	243	32	0	25	52	16	0	13	306	12	0	838
Total	332	214	27	0	69	922	158	0	89	315	167	0	71	1521	67	0	3952
*** BREAK ***																	
11:00	63	47	11	0	22	248	64	1	16	23	23	0	10	246	4	0	778
11:15	67	36	4	0	25	230	72	0	24	29	22	0	13	247	5	0	774
11:30	55	45	5	0	32	231	73	0	19	31	23	0	26	280	15	0	835
11:45	57	56	5	0	35	230	72	0	21	55	24	0	20	292	6	0	873
Total	242	184	25	0	114	939	281	1	80	138	92	0	69	1065	30	0	3260
12:00	50	56	2	0	30	244	75	0	26	41	25	0	21	242	5	0	817
12:15	66	56	6	0	40	212	69	0	32	42	20	0	14	276	12	0	845
12:30	65	38	4	0	32	239	79	0	26	32	37	0	21	276	6	0	855
12:45	71	46	4	0	33	244	80	0	22	49	34	0	20	257	10	0	870
Total	252	196	16	0	135	939	303	0	106	164	116	0	76	1051	33	0	3387
*** BREAK ***																	
15:00	85	101	25	0	24	317	65	0	24	50	19	0	26	323	20	0	1079
15:15	46	75	29	0	17	297	85	0	25	59	22	0	17	319	17	0	1008
15:30	53	67	21	0	37	337	88	0	27	82	28	0	17	297	21	0	1075
15:45	62	64	17	0	24	311	87	0	23	73	20	0	22	301	21	0	1025
Total	246	307	92	0	102	1262	325	0	99	264	89	0	82	1240	79	0	4187
16:00	70	89	32	0	29	371	100	0	31	33	20	0	19	289	19	0	1102
16:15	46	62	26	0	26	353	99	0	17	62	19	0	19	272	22	0	1023
16:30	72	93	30	0	31	356	122	0	33	71	19	0	33	329	11	0	1200
16:45	61	78	36	0	20	405	103	0	17	81	20	0	40	262	21	0	1144
Total	249	322	124	0	106	1485	424	0	98	247	78	0	111	1152	73	0	4469
17:00	72	123	37	0	41	357	124	0	42	105	15	0	26	308	18	0	1268
17:15	75	113	34	0	35	405	141	0	25	108	19	0	43	275	28	0	1301
17:30	90	132	49	0	35	425	117	3	36	117	21	0	33	272	21	0	1351
17:45	82	115	36	0	37	380	118	0	26	107	10	0	27	267	24	0	1229
Total	319	483	156	0	148	1567	500	3	129	437	65	0	129	1122	91	0	5149
Grand Total	2213	1985	473	0	792	8686	2281	4	718	2035	849	0	634	10409	437	0	31516
Apprch %	47.4	42.5	10.1	0	6.7	73.8	19.4	0	19.9	56.5	23.6	0	5.5	90.7	3.8	0	
Total %	7	6.3	1.5	0	2.5	27.6	7.2	0	2.3	6.5	2.7	0	2	33	1.4	0	



MINNESOTA DEPT OF TRANSPORTATION

TRAFFIC DATA COLLECTION - METRO

TH-5 at Eden Prairie Rd / CSAH-4
 Ref.Pt.: 047.044
 Data by: Westwood Professional Services
 TURN MOVEMENT COUNT

File Name : TH-5 at Eden Prairie Rd CSAH-4 2008
 Site Code : 15052417
 Start Date : 9/17/2008
 Page No : 2

Start Time	Eden Prairie Rd. / CSAH-4 Southbound					TH-5 Westbound					Eden Prairie Rd. / CSAH-4 Northbound					TH-5 Eastbound					Int. Total
	Left	Thru	Right	Peds	App. Total	Left	Thru	Right	Peds	App. Total	Left	Thru	Right	Peds	App. Total	Left	Thru	Right	Peds	App. Total	
Peak Hour Analysis From 06:00 to 08:45 - Peak 1 of 1																					
Peak Hour for Entire Intersection Begins at 07:15																					
07:15	114	43	1	0	158	15	196	81	0	292	22	109	29	0	160	16	485	11	0	512	1122
07:30	109	66	8	0	183	19	219	54	0	292	15	97	48	0	160	12	534	8	0	554	1189
07:45	69	67	4	0	140	20	257	43	0	320	15	91	69	0	175	21	529	9	0	559	1194
08:00	86	50	6	0	142	13	216	71	0	300	18	128	69	0	215	23	471	19	0	513	1170
Total Volume	378	226	19	0	623	67	888	249	0	1204	70	425	215	0	710	72	2019	47	0	2138	4675
% App. Total	60.7	36.3	3	0		5.6	73.8	20.7	0		9.9	59.9	30.3	0		3.4	94.4	2.2	0		
PHF	.829	.843	.594	.000	.851	.838	.864	.769	.000	.941	.795	.830	.779	.000	.826	.783	.945	.618	.000	.956	.979

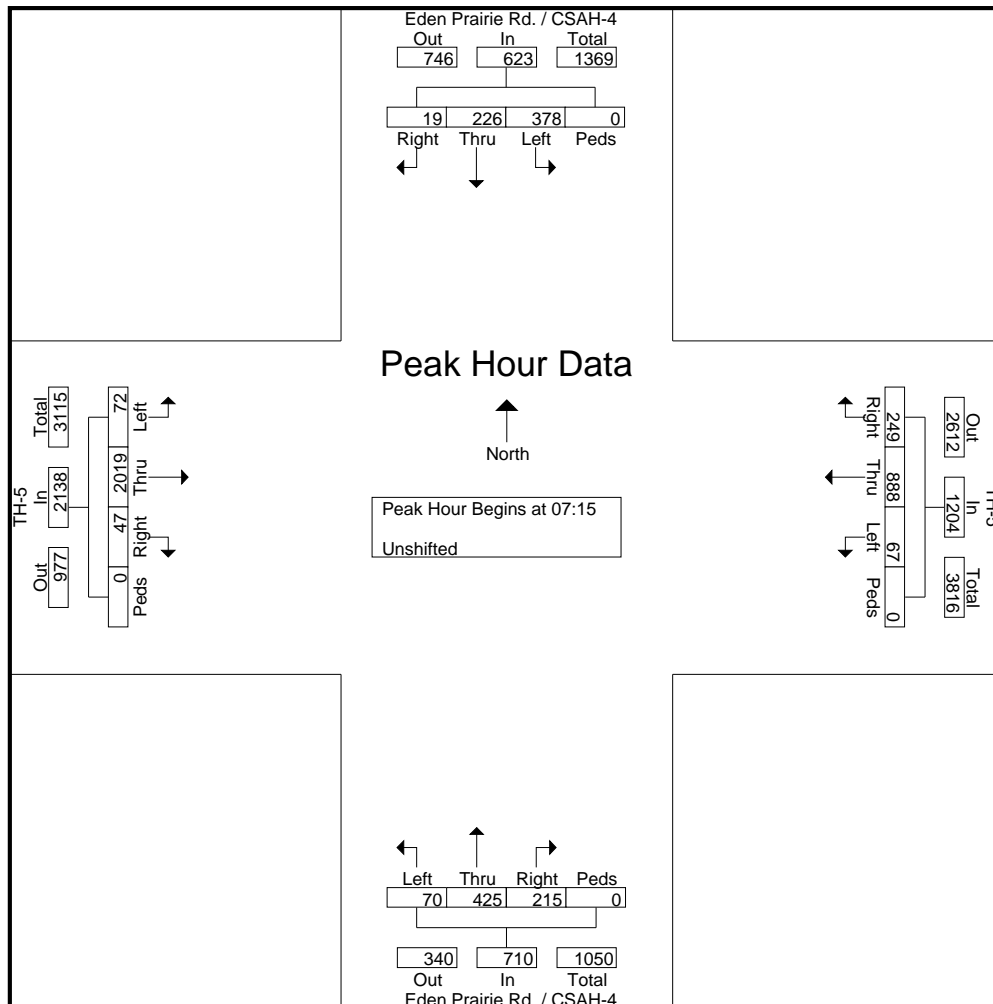



MINNESOTA DEPT OF TRANSPORTATION

TRAFFIC DATA COLLECTION - METRO

TH-5 at Eden Prairie Rd / CSAH-4
 Ref.Pt.: 047.044
 Data by: Westwood Professional Services
 TURN MOVEMENT COUNT

File Name : TH-5 at Eden Prairie Rd CSAH-4 2008
 Site Code : 15052417
 Start Date : 9/17/2008
 Page No : 3

Start Time	Eden Prairie Rd. / CSAH-4 Southbound					TH-5 Westbound					Eden Prairie Rd. / CSAH-4 Northbound					TH-5 Eastbound					Int. Total
	Left	Thru	Right	Peds	App. Total	Left	Thru	Right	Peds	App. Total	Left	Thru	Right	Peds	App. Total	Left	Thru	Right	Peds	App. Total	

Peak Hour Analysis From 15:00 to 17:45 - Peak 1 of 1

Peak Hour for Entire Intersection Begins at 17:00

17:00	72	123	37	0	232	41	357	124	0	522	42	105	15	0	162	26	308	18	0	352	1268
17:15	75	113	34	0	222	35	405	141	0	581	25	108	19	0	152	43	275	28	0	346	1301
17:30	90	132	49	0	271	35	425	117	3	580	36	117	21	0	174	33	272	21	0	326	1351
17:45	82	115	36	0	233	37	380	118	0	535	26	107	10	0	143	27	267	24	0	318	1229
Total Volume	319	483	156	0	958	148	1567	500	3	2218	129	437	65	0	631	129	1122	91	0	1342	5149
% App. Total	33.3	50.4	16.3	0		6.7	70.6	22.5	0.1		20.4	69.3	10.3	0		9.6	83.6	6.8	0		
PHF	.886	.915	.796	.000	.884	.902	.922	.887	.250	.954	.768	.934	.774	.000	.907	.750	.911	.813	.000	.953	.953

