



# MINNESOTA DEPT OF TRANSPORTATION

## TRAFFIC DATA COLLECTION - METRO

Location: TH-5 AT CHERRY ST. WACONIA  
 Ref.Pt.: 031.711  
 JAMAR# 632 DR  
 TURN MOVEMENT COUNT

File Name : TH 5 AT CHERRY AND TENTH ST 2008  
 Site Code : 00000000  
 Start Date : 11/19/2008  
 Page No : 1

### Groups Printed- Unshifted

| Start Time    | CHERRY ST Southbound |      |       |      | TH 5 Westbound |      |       |      | TENTH ST Northbound |      |       |      | TH 5 Eastbound |      |       |      | Int. Total |
|---------------|----------------------|------|-------|------|----------------|------|-------|------|---------------------|------|-------|------|----------------|------|-------|------|------------|
|               | Left                 | Thru | Right | Peds | Left           | Thru | Right | Peds | Left                | Thru | Right | Peds | Left           | Thru | Right | Peds |            |
| 06:00         | 1                    | 0    | 0     | 0    | 0              | 15   | 10    | 0    | 0                   | 0    | 0     | 0    | 16             | 79   | 2     | 0    | 123        |
| 06:15         | 1                    | 0    | 5     | 0    | 0              | 33   | 22    | 0    | 0                   | 0    | 0     | 0    | 24             | 106  | 3     | 0    | 194        |
| 06:30         | 0                    | 0    | 3     | 0    | 0              | 38   | 19    | 0    | 0                   | 0    | 2     | 0    | 30             | 109  | 6     | 0    | 207        |
| 06:45         | 0                    | 0    | 3     | 0    | 0              | 57   | 17    | 0    | 0                   | 0    | 0     | 0    | 53             | 129  | 5     | 0    | 264        |
| Total         | 2                    | 0    | 11    | 0    | 0              | 143  | 68    | 0    | 0                   | 0    | 2     | 0    | 123            | 423  | 16    | 0    | 788        |
| 07:00         | 2                    | 0    | 6     | 0    | 0              | 58   | 8     | 0    | 0                   | 0    | 1     | 0    | 13             | 143  | 6     | 0    | 237        |
| 07:15         | 2                    | 0    | 7     | 0    | 0              | 83   | 15    | 0    | 0                   | 0    | 0     | 0    | 35             | 139  | 14    | 0    | 295        |
| 07:30         | 2                    | 0    | 9     | 0    | 0              | 114  | 18    | 0    | 0                   | 0    | 0     | 0    | 27             | 196  | 18    | 0    | 384        |
| 07:45         | 2                    | 0    | 10    | 0    | 0              | 110  | 21    | 0    | 0                   | 0    | 0     | 0    | 52             | 202  | 16    | 0    | 413        |
| Total         | 8                    | 0    | 32    | 0    | 0              | 365  | 62    | 0    | 0                   | 0    | 1     | 0    | 127            | 680  | 54    | 0    | 1329       |
| 08:00         | 2                    | 0    | 9     | 0    | 0              | 90   | 11    | 0    | 0                   | 0    | 0     | 0    | 30             | 148  | 5     | 0    | 295        |
| 08:15         | 3                    | 0    | 9     | 0    | 0              | 68   | 12    | 0    | 0                   | 0    | 0     | 0    | 42             | 107  | 4     | 0    | 245        |
| 08:30         | 6                    | 0    | 12    | 0    | 0              | 80   | 18    | 0    | 0                   | 0    | 1     | 0    | 42             | 120  | 4     | 0    | 283        |
| 08:45         | 7                    | 0    | 5     | 0    | 0              | 58   | 23    | 0    | 0                   | 0    | 0     | 0    | 37             | 80   | 3     | 0    | 213        |
| Total         | 18                   | 0    | 35    | 0    | 0              | 296  | 64    | 0    | 0                   | 0    | 1     | 0    | 151            | 455  | 16    | 0    | 1036       |
| *** BREAK *** |                      |      |       |      |                |      |       |      |                     |      |       |      |                |      |       |      |            |
| 15:00         | 12                   | 0    | 32    | 0    | 0              | 168  | 8     | 0    | 0                   | 0    | 0     | 0    | 31             | 147  | 3     | 0    | 401        |
| 15:15         | 36                   | 0    | 37    | 0    | 0              | 145  | 16    | 0    | 0                   | 0    | 1     | 0    | 24             | 106  | 9     | 0    | 374        |
| 15:30         | 10                   | 0    | 46    | 0    | 0              | 149  | 18    | 0    | 0                   | 0    | 5     | 0    | 21             | 93   | 6     | 0    | 348        |
| 15:45         | 10                   | 0    | 35    | 0    | 0              | 132  | 11    | 0    | 0                   | 0    | 0     | 0    | 18             | 101  | 0     | 0    | 307        |
| Total         | 68                   | 0    | 150   | 0    | 0              | 594  | 53    | 0    | 0                   | 0    | 6     | 0    | 94             | 447  | 18    | 0    | 1430       |
| 16:00         | 6                    | 0    | 36    | 0    | 0              | 166  | 10    | 0    | 0                   | 0    | 2     | 0    | 20             | 118  | 2     | 0    | 360        |
| 16:15         | 8                    | 0    | 39    | 0    | 0              | 155  | 13    | 0    | 0                   | 0    | 3     | 0    | 22             | 89   | 0     | 0    | 329        |
| 16:30         | 16                   | 0    | 45    | 0    | 0              | 178  | 11    | 0    | 0                   | 0    | 2     | 0    | 12             | 103  | 2     | 0    | 369        |
| 16:45         | 2                    | 0    | 40    | 0    | 0              | 178  | 9     | 0    | 0                   | 0    | 0     | 0    | 14             | 105  | 3     | 0    | 351        |
| Total         | 32                   | 0    | 160   | 0    | 0              | 677  | 43    | 0    | 0                   | 0    | 7     | 0    | 68             | 415  | 7     | 0    | 1409       |
| 17:00         | 3                    | 0    | 38    | 0    | 0              | 181  | 9     | 0    | 0                   | 0    | 2     | 0    | 14             | 126  | 0     | 0    | 373        |
| 17:15         | 13                   | 0    | 43    | 0    | 0              | 168  | 2     | 0    | 0                   | 0    | 1     | 0    | 13             | 108  | 5     | 0    | 353        |
| 17:30         | 2                    | 0    | 29    | 0    | 0              | 189  | 5     | 0    | 0                   | 0    | 2     | 0    | 13             | 113  | 2     | 0    | 355        |
| 17:45         | 5                    | 0    | 26    | 0    | 0              | 166  | 6     | 0    | 0                   | 0    | 1     | 0    | 16             | 99   | 2     | 0    | 321        |
| Total         | 23                   | 0    | 136   | 0    | 0              | 704  | 22    | 0    | 0                   | 0    | 6     | 0    | 56             | 446  | 9     | 0    | 1402       |
| Grand Total   | 151                  | 0    | 524   | 0    | 0              | 2779 | 312   | 0    | 0                   | 0    | 23    | 0    | 619            | 2866 | 120   | 0    | 7394       |
| Apprch %      | 22.4                 | 0    | 77.6  | 0    | 0              | 89.9 | 10.1  | 0    | 0                   | 0    | 100   | 0    | 17.2           | 79.5 | 3.3   | 0    |            |
| Total %       | 2                    | 0    | 7.1   | 0    | 0              | 37.6 | 4.2   | 0    | 0                   | 0    | 0.3   | 0    | 8.4            | 38.8 | 1.6   | 0    |            |



# MINNESOTA DEPT OF TRANSPORTATION

## TRAFFIC DATA COLLECTION - METRO

Location: TH-5 AT CHERRY ST. WACONIA  
 Ref.Pt.: 031.711  
 JAMAR# 632 DR  
 TURN MOVEMENT COUNT

File Name : TH 5 AT CHERRY AND TENTH ST 2008  
 Site Code : 00000000  
 Start Date : 11/19/2008  
 Page No : 2

| Start Time  | CHERRY ST Southbound |      |       |      |            | TH 5 Westbound |      |       |      |            | TENTH ST Northbound |      |       |      |            | TH 5 Eastbound |      |       |      |            | Int. Total |
|---|----------------------|------|-------|------|------------|----------------|------|-------|------|------------|---------------------|------|-------|------|------------|----------------|------|-------|------|------------|------------|
|   | Left                 | Thru | Right | Peds | App. Total | Left           | Thru | Right | Peds | App. Total | Left                | Thru | Right | Peds | App. Total | Left           | Thru | Right | Peds | App. Total |            |
| <b>Peak Hour Analysis From 06:00 to 08:45 - Peak 1 of 1</b> |                      |      |       |      |            |                |      |       |      |            |                     |      |       |      |            |                |      |       |      |            |            |
| Peak Hour for Entire Intersection Begins at 07:15           |                      |      |       |      |            |                |      |       |      |            |                     |      |       |      |            |                |      |       |      |            |            |
| 07:15   | 2                    | 0    | 7     | 0    | 9          | 0              | 83   | 15    | 0    | 98         | 0                   | 0    | 0     | 0    | 0          | 35             | 139  | 14    | 0    | 188        | 295        |
| 07:30   | 2                    | 0    | 9     | 0    | 11         | 0              | 114  | 18    | 0    | 132        | 0                   | 0    | 0     | 0    | 0          | 27             | 196  | 18    | 0    | 241        | 384        |
| 07:45   | 2                    | 0    | 10    | 0    | 12         | 0              | 110  | 21    | 0    | 131        | 0                   | 0    | 0     | 0    | 0          | 52             | 202  | 16    | 0    | 270        | 413        |
| 08:00   | 2                    | 0    | 9     | 0    | 11         | 0              | 90   | 11    | 0    | 101        | 0                   | 0    | 0     | 0    | 0          | 30             | 148  | 5     | 0    | 183        | 295        |
| Total Volume  | 8                    | 0    | 35    | 0    | 43         | 0              | 397  | 65    | 0    | 462        | 0                   | 0    | 0     | 0    | 0          | 144            | 685  | 53    | 0    | 882        | 1387       |
| % App. Total  |                      |      |       |      |            |                |      |       |      |            |                     |      |       |      |            |                |      |       |      |            |            |
| PHF   | 1.000                | .000 | .875  | .000 | .896       | .000           | .871 | .774  | .000 | .875       | .000                | .000 | .000  | .000 | .000       | .692           | .848 | .736  | .000 | .817       | .840       |

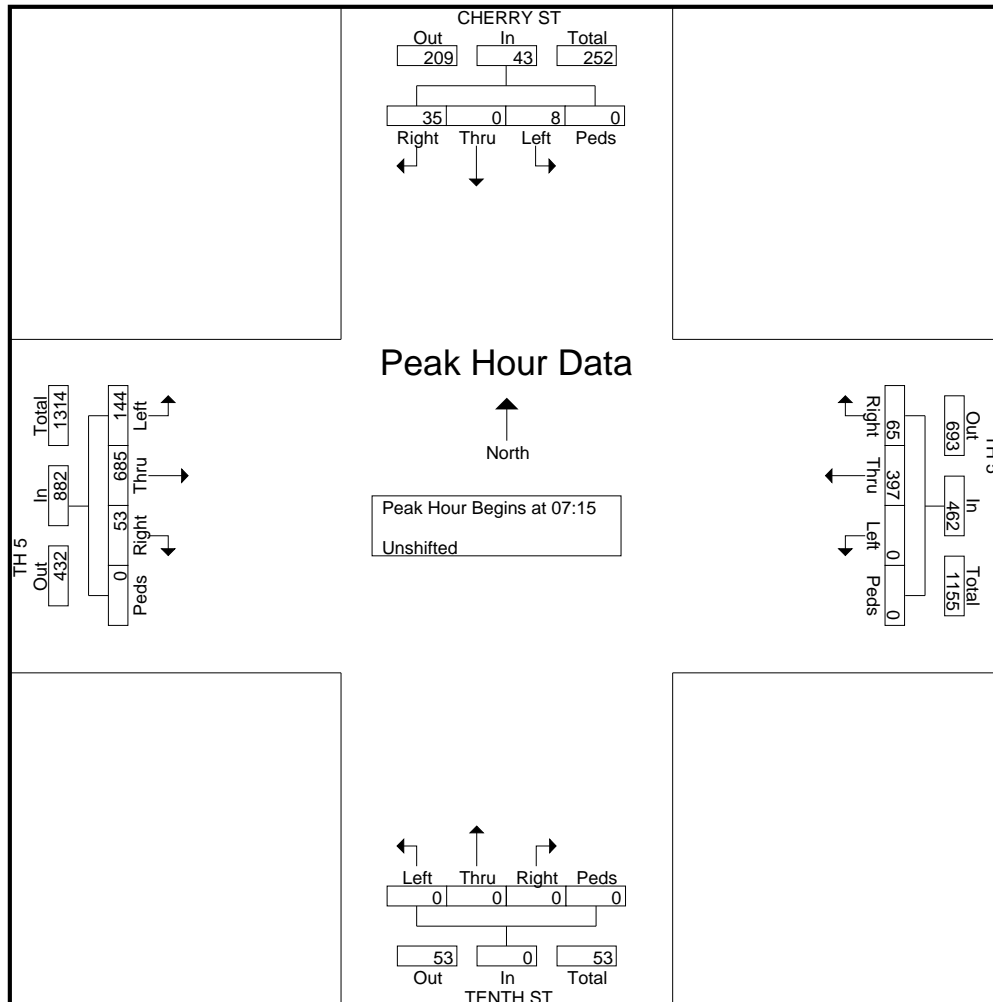



# MINNESOTA DEPT OF TRANSPORTATION

## TRAFFIC DATA COLLECTION - METRO

Location: TH-5 AT CHERRY ST. WACONIA  
 Ref.Pt.: 031.711  
 JAMAR# 632 DR  
 TURN MOVEMENT COUNT

File Name : TH 5 AT CHERRY AND TENTH ST 2008  
 Site Code : 00000000  
 Start Date : 11/19/2008  
 Page No : 3

| Start Time   | CHERRY ST Southbound |      |       |      |            | TH 5 Westbound |      |       |      |            | TENTH ST Northbound |      |       |      |            | TH 5 Eastbound |      |       |      |            | Int. Total |
|--|----------------------|------|-------|------|------------|----------------|------|-------|------|------------|---------------------|------|-------|------|------------|----------------|------|-------|------|------------|------------|
|  | Left                 | Thru | Right | Peds | App. Total | Left           | Thru | Right | Peds | App. Total | Left                | Thru | Right | Peds | App. Total | Left           | Thru | Right | Peds | App. Total |            |
| Peak Hour Analysis From 15:00 to 17:45 - Peak 1 of 1 |                      |      |       |      |            |                |      |       |      |            |                     |      |       |      |            |                |      |       |      |            |            |
| Peak Hour for Entire Intersection Begins at 16:30    |                      |      |       |      |            |                |      |       |      |            |                     |      |       |      |            |                |      |       |      |            |            |
| 16:30  | 16                   | 0    | 45    | 0    | 61         | 0              | 178  | 11    | 0    | 189        | 0                   | 0    | 2     | 0    | 2          | 12             | 103  | 2     | 0    | 117        | 369        |
| 16:45  | 2                    | 0    | 40    | 0    | 42         | 0              | 178  | 9     | 0    | 187        | 0                   | 0    | 0     | 0    | 0          | 14             | 105  | 3     | 0    | 122        | 351        |
| 17:00  | 3                    | 0    | 38    | 0    | 41         | 0              | 181  | 9     | 0    | 190        | 0                   | 0    | 2     | 0    | 2          | 14             | 126  | 0     | 0    | 140        | 373        |
| 17:15  | 13                   | 0    | 43    | 0    | 56         | 0              | 168  | 2     | 0    | 170        | 0                   | 0    | 1     | 0    | 1          | 13             | 108  | 5     | 0    | 126        | 353        |
| Total Volume   | 34                   | 0    | 166   | 0    | 200        | 0              | 705  | 31    | 0    | 736        | 0                   | 0    | 5     | 0    | 5          | 53             | 442  | 10    | 0    | 505        | 1446       |
| % App. Total   |                      |      |       |      |            |                |      |       |      |            |                     |      |       |      |            |                |      |       |      |            |            |
| PHF  | .531                 | .000 | .922  | .000 | .820       | .000           | .974 | .705  | .000 | .968       | .000                | .000 | .625  | .000 | .625       | .946           | .877 | .500  | .000 | .902       | .969       |

