

TRAFFIC DATA INC.

3268 Xenwood Ave S
St Louis Park, MN 55416

Oak Ave at Community Drive WACONIA
North of TH-5
TDI Inc
TURN MOVEMENT COUNT

File Name : 2681112 Oak & Community
Site Code : 2681112
Start Date : 2/16/2011
Page No : 1

Groups Printed- Class 1

| Start Time | Oak Ave Southbound | | | | commercial entrance Westbound | | | | Oak Ave Northbound | | | | Community Drive Eastbound | | | | Int. Total |
|------------|--------------------|------|-------|------|-------------------------------|------|-------|------|--------------------|------|-------|------|---------------------------|------|-------|------|------------|
| | Left | Thru | Right | Peds | Left | Thru | Right | Peds | Left | Thru | Right | Peds | Left | Thru | Right | Peds | |
| 06:00 | 2 | 12 | 2 | 0 | 5 | 0 | 3 | 0 | 4 | 4 | 0 | 0 | 0 | 1 | 3 | 0 | 36 |
| 06:15 | 2 | 6 | 1 | 0 | 6 | 0 | 0 | 0 | 3 | 4 | 0 | 0 | 8 | 0 | 9 | 0 | 39 |
| 06:30 | 3 | 17 | 1 | 0 | 3 | 0 | 0 | 0 | 10 | 6 | 0 | 0 | 2 | 0 | 7 | 0 | 49 |
| 06:45 | 6 | 14 | 7 | 0 | 8 | 1 | 3 | 0 | 19 | 6 | 0 | 0 | 4 | 2 | 6 | 0 | 76 |
| Total | 13 | 49 | 11 | 0 | 22 | 1 | 6 | 0 | 36 | 20 | 0 | 0 | 14 | 3 | 25 | 0 | 200 |
| 07:00 | 6 | 6 | 11 | 0 | 3 | 0 | 0 | 0 | 36 | 10 | 0 | 0 | 4 | 0 | 10 | 0 | 86 |
| 07:15 | 3 | 11 | 21 | 0 | 4 | 1 | 2 | 0 | 95 | 18 | 0 | 0 | 7 | 1 | 34 | 0 | 197 |
| 07:30 | 6 | 10 | 39 | 0 | 3 | 6 | 3 | 0 | 118 | 6 | 0 | 0 | 42 | 3 | 73 | 0 | 309 |
| 07:45 | 1 | 3 | 28 | 2 | 2 | 3 | 3 | 0 | 74 | 0 | 0 | 0 | 61 | 3 | 82 | 0 | 262 |
| Total | 16 | 30 | 99 | 2 | 12 | 10 | 8 | 0 | 323 | 34 | 0 | 0 | 114 | 7 | 199 | 0 | 854 |
| 08:00 | 2 | 13 | 1 | 0 | 3 | 0 | 4 | 0 | 20 | 12 | 0 | 0 | 8 | 0 | 12 | 0 | 75 |
| 08:15 | 0 | 9 | 2 | 0 | 2 | 0 | 0 | 0 | 3 | 9 | 0 | 0 | 3 | 0 | 13 | 0 | 41 |
| 08:30 | 3 | 8 | 2 | 0 | 1 | 1 | 0 | 0 | 16 | 5 | 0 | 0 | 2 | 1 | 8 | 0 | 47 |
| 08:45 | 2 | 8 | 3 | 0 | 2 | 0 | 2 | 0 | 11 | 7 | 0 | 0 | 1 | 1 | 5 | 0 | 42 |
| Total | 7 | 38 | 8 | 0 | 8 | 1 | 6 | 0 | 50 | 33 | 0 | 0 | 14 | 2 | 38 | 0 | 205 |
| 09:00 | 2 | 5 | 1 | 0 | 4 | 2 | 1 | 0 | 16 | 5 | 0 | 0 | 3 | 0 | 9 | 0 | 48 |
| 09:15 | 2 | 6 | 3 | 0 | 5 | 0 | 5 | 0 | 10 | 5 | 0 | 0 | 3 | 0 | 13 | 0 | 52 |
| 09:30 | 1 | 4 | 1 | 0 | 4 | 0 | 2 | 0 | 4 | 5 | 0 | 0 | 3 | 1 | 8 | 0 | 33 |
| 09:45 | 1 | 1 | 1 | 0 | 1 | 0 | 0 | 0 | 8 | 8 | 1 | 0 | 2 | 0 | 8 | 0 | 31 |
| Total | 6 | 16 | 6 | 0 | 14 | 2 | 8 | 0 | 38 | 23 | 1 | 0 | 11 | 1 | 38 | 0 | 164 |
| 10:00 | 1 | 11 | 0 | 0 | 0 | 1 | 4 | 1 | 8 | 5 | 0 | 0 | 1 | 2 | 4 | 0 | 38 |
| 10:15 | 2 | 3 | 1 | 2 | 5 | 1 | 1 | 0 | 4 | 5 | 0 | 0 | 2 | 2 | 11 | 0 | 39 |
| 10:30 | 0 | 6 | 2 | 0 | 3 | 2 | 2 | 0 | 7 | 6 | 1 | 0 | 7 | 0 | 16 | 0 | 52 |
| 10:45 | 1 | 7 | 1 | 0 | 5 | 0 | 1 | 0 | 6 | 1 | 0 | 0 | 6 | 0 | 6 | 0 | 34 |
| Total | 4 | 27 | 4 | 2 | 13 | 4 | 8 | 1 | 25 | 17 | 1 | 0 | 16 | 4 | 37 | 0 | 163 |
| 11:00 | 2 | 4 | 3 | 0 | 4 | 1 | 0 | 0 | 5 | 10 | 0 | 0 | 10 | 1 | 1 | 0 | 41 |
| 11:15 | 1 | 12 | 2 | 0 | 6 | 1 | 5 | 0 | 4 | 5 | 1 | 0 | 6 | 2 | 4 | 0 | 49 |
| 11:30 | 0 | 7 | 2 | 0 | 3 | 0 | 4 | 0 | 5 | 9 | 0 | 0 | 2 | 1 | 7 | 0 | 40 |
| 11:45 | 3 | 8 | 3 | 0 | 3 | 1 | 3 | 0 | 4 | 10 | 0 | 0 | 8 | 2 | 7 | 0 | 52 |
| Total | 6 | 31 | 10 | 0 | 16 | 3 | 12 | 0 | 18 | 34 | 1 | 0 | 26 | 6 | 19 | 0 | 182 |
| 12:00 | 4 | 8 | 1 | 0 | 12 | 1 | 8 | 0 | 10 | 5 | 1 | 0 | 11 | 2 | 12 | 0 | 75 |
| 12:15 | 2 | 10 | 2 | 0 | 4 | 0 | 6 | 0 | 8 | 6 | 1 | 0 | 5 | 1 | 12 | 0 | 57 |
| 12:30 | 4 | 9 | 0 | 2 | 6 | 1 | 2 | 0 | 5 | 3 | 0 | 0 | 1 | 0 | 3 | 0 | 36 |
| 12:45 | 1 | 7 | 4 | 0 | 5 | 0 | 2 | 0 | 9 | 6 | 0 | 0 | 4 | 1 | 11 | 0 | 50 |
| Total | 11 | 34 | 7 | 2 | 27 | 2 | 18 | 0 | 32 | 20 | 2 | 0 | 21 | 4 | 38 | 0 | 218 |
| 13:00 | 2 | 4 | 9 | 2 | 10 | 1 | 3 | 0 | 7 | 6 | 0 | 0 | 3 | 1 | 11 | 0 | 59 |
| 13:15 | 1 | 3 | 3 | 0 | 2 | 3 | 5 | 0 | 13 | 6 | 0 | 0 | 0 | 0 | 9 | 0 | 45 |
| 13:30 | 2 | 2 | 2 | 0 | 6 | 0 | 2 | 0 | 7 | 9 | 0 | 0 | 3 | 1 | 9 | 0 | 43 |
| 13:45 | 4 | 5 | 1 | 0 | 8 | 1 | 1 | 1 | 6 | 7 | 0 | 0 | 4 | 3 | 8 | 0 | 49 |
| Total | 9 | 14 | 15 | 2 | 26 | 5 | 11 | 1 | 33 | 28 | 0 | 0 | 10 | 5 | 37 | 0 | 196 |
| 14:00 | 5 | 3 | 2 | 1 | 7 | 1 | 4 | 0 | 13 | 7 | 0 | 0 | 1 | 1 | 5 | 0 | 50 |
| 14:15 | 3 | 12 | 5 | 3 | 4 | 0 | 3 | 0 | 10 | 6 | 0 | 0 | 2 | 1 | 14 | 2 | 65 |
| 14:30 | 2 | 10 | 9 | 1 | 5 | 0 | 2 | 0 | 33 | 5 | 0 | 0 | 0 | 0 | 18 | 0 | 85 |
| 14:45 | 3 | 20 | 19 | 3 | 4 | 2 | 7 | 0 | 47 | 6 | 0 | 0 | 49 | 5 | 90 | 0 | 255 |
| Total | 13 | 45 | 35 | 8 | 20 | 3 | 16 | 0 | 103 | 24 | 0 | 0 | 52 | 7 | 127 | 2 | 455 |
| 15:00 | 4 | 12 | 13 | 1 | 6 | 3 | 2 | 0 | 43 | 19 | 0 | 0 | 67 | 3 | 147 | 0 | 320 |
| 15:15 | 3 | 12 | 3 | 0 | 4 | 0 | 5 | 0 | 11 | 9 | 1 | 0 | 15 | 2 | 37 | 0 | 102 |
| 15:30 | 6 | 9 | 0 | 4 | 12 | 2 | 8 | 0 | 12 | 15 | 1 | 0 | 3 | 3 | 25 | 0 | 100 |

TRAFFIC DATA INC.

3268 Xenwood Ave S
St Louis Park, MN 55416

Oak Ave at Community Drive WACONIA
North of TH-5
TDI Inc
TURN MOVEMENT COUNT

File Name : 2681112 Oak & Community
Site Code : 2681112
Start Date : 2/16/2011
Page No : 2

Groups Printed- Class 1

| Start Time | Oak Ave Southbound | | | | commercial entrance Westbound | | | | Oak Ave Northbound | | | | Community Drive Eastbound | | | | Int. Total |
|-------------|--------------------|------|------|------|-------------------------------|------|------|------|--------------------|------|------|------|---------------------------|------|------|------|------------|
| | Left | Thru | Rght | Peds | Left | Thru | Rght | Peds | Left | Thru | Rght | Peds | Left | Thru | Rght | Peds | |
| 15:45 | 4 | 11 | 3 | 0 | 11 | 2 | 11 | 0 | 23 | 7 | 2 | 0 | 14 | 6 | 23 | 1 | 118 |
| Total | 17 | 44 | 19 | 5 | 33 | 7 | 26 | 0 | 89 | 50 | 4 | 0 | 99 | 14 | 232 | 1 | 640 |
| 16:00 | 0 | 14 | 4 | 0 | 9 | 1 | 4 | 2 | 28 | 14 | 0 | 0 | 13 | 1 | 25 | 0 | 115 |
| 16:15 | 3 | 24 | 10 | 0 | 7 | 0 | 6 | 2 | 25 | 21 | 0 | 0 | 3 | 2 | 22 | 0 | 125 |
| 16:30 | 5 | 23 | 4 | 0 | 10 | 2 | 3 | 0 | 22 | 27 | 0 | 0 | 7 | 1 | 25 | 1 | 130 |
| 16:45 | 6 | 17 | 8 | 0 | 8 | 1 | 11 | 0 | 27 | 21 | 0 | 0 | 13 | 1 | 16 | 0 | 129 |
| Total | 14 | 78 | 26 | 0 | 34 | 4 | 24 | 4 | 102 | 83 | 0 | 0 | 36 | 5 | 88 | 1 | 499 |
| 17:00 | 3 | 26 | 11 | 0 | 5 | 0 | 9 | 0 | 38 | 22 | 0 | 0 | 7 | 1 | 32 | 0 | 154 |
| 17:15 | 5 | 19 | 6 | 0 | 12 | 0 | 11 | 0 | 28 | 16 | 0 | 0 | 6 | 2 | 25 | 2 | 132 |
| 17:30 | 2 | 17 | 5 | 2 | 5 | 3 | 7 | 0 | 17 | 14 | 0 | 0 | 5 | 3 | 44 | 0 | 124 |
| 17:45 | 3 | 15 | 5 | 0 | 10 | 1 | 7 | 2 | 34 | 27 | 1 | 0 | 17 | 3 | 22 | 4 | 151 |
| Total | 13 | 77 | 27 | 2 | 32 | 4 | 34 | 2 | 117 | 79 | 1 | 0 | 35 | 9 | 123 | 6 | 561 |
| 18:00 | 6 | 25 | 4 | 1 | 8 | 1 | 7 | 0 | 24 | 24 | 1 | 0 | 11 | 4 | 38 | 0 | 154 |
| 18:15 | 2 | 25 | 3 | 0 | 13 | 1 | 7 | 0 | 17 | 25 | 0 | 0 | 2 | 0 | 15 | 0 | 110 |
| 18:30 | 5 | 21 | 6 | 0 | 17 | 0 | 6 | 0 | 7 | 21 | 0 | 0 | 2 | 1 | 18 | 0 | 104 |
| 18:45 | 4 | 17 | 3 | 0 | 6 | 1 | 5 | 0 | 31 | 9 | 0 | 0 | 4 | 1 | 9 | 1 | 91 |
| Total | 17 | 88 | 16 | 1 | 44 | 3 | 25 | 0 | 79 | 79 | 1 | 0 | 19 | 6 | 80 | 1 | 459 |
| Grand Total | 146 | 571 | 283 | 24 | 301 | 49 | 202 | 8 | 1045 | 524 | 11 | 0 | 467 | 73 | 1081 | 11 | 4796 |
| Apprch % | 14.3 | 55.8 | 27.6 | 2.3 | 53.8 | 8.8 | 36.1 | 1.4 | 66.1 | 33.2 | 0.7 | 0 | 28.6 | 4.5 | 66.2 | 0.7 | |
| Total % | 3 | 11.9 | 5.9 | 0.5 | 6.3 | 1 | 4.2 | 0.2 | 21.8 | 10.9 | 0.2 | 0 | 9.7 | 1.5 | 22.5 | 0.2 | |

TRAFFIC DATA INC.

3268 Xenwood Ave S
St Louis Park, MN 55416

Oak Ave at Community Drive WACONIA
North of TH-5
TDI Inc
TURN MOVEMENT COUNT

File Name : 2681112 Oak & Community
Site Code : 2681112
Start Date : 2/16/2011
Page No : 3

| Start Time | Oak Ave Southbound | | | | | commercial entrance Westbound | | | | | Oak Ave Northbound | | | | | Community Drive Eastbound | | | | | Int. Total |
|--|--------------------|------|------|------|------------|-------------------------------|------|------|------|------------|--------------------|------|------|------|------------|---------------------------|------|------|------|------------|------------|
| | Left | Thru | Rght | Peds | App. Total | Left | Thru | Rght | Peds | App. Total | Left | Thru | Rght | Peds | App. Total | Left | Thru | Rght | Peds | App. Total | |
| Peak Hour Analysis From 06:00 to 09:30 - Peak 1 of 1 | | | | | | | | | | | | | | | | | | | | | |
| Peak Hour for Entire Intersection Begins at 07:00 | | | | | | | | | | | | | | | | | | | | | |
| 07:00 | 6 | 6 | 11 | 0 | 23 | 3 | 0 | 0 | 0 | 3 | 36 | 10 | 0 | 0 | 46 | 4 | 0 | 10 | 0 | 14 | 86 |
| 07:15 | 3 | 11 | 21 | 0 | 35 | 4 | 1 | 2 | 0 | 7 | 95 | 18 | 0 | 0 | 113 | 7 | 1 | 34 | 0 | 42 | 197 |
| 07:30 | 6 | 10 | 39 | 0 | 55 | 3 | 6 | 3 | 0 | 12 | 118 | 6 | 0 | 0 | 124 | 42 | 3 | 73 | 0 | 118 | 309 |
| 07:45 | 1 | 3 | 28 | 2 | 34 | 2 | 3 | 3 | 0 | 8 | 74 | 0 | 0 | 0 | 74 | 61 | 3 | 82 | 0 | 146 | 262 |
| Total Volume | 16 | 30 | 99 | 2 | 147 | 12 | 10 | 8 | 0 | 30 | 323 | 34 | 0 | 0 | 357 | 114 | 7 | 199 | 0 | 320 | 854 |
| % App. Total | 10.9 | 20.4 | 67.3 | 1.4 | | 40 | 33.3 | 26.7 | 0 | | 90.5 | 9.5 | 0 | 0 | | 35.6 | 2.2 | 62.2 | 0 | | |
| PHF | .667 | .682 | .635 | .250 | .668 | .750 | .417 | .667 | .000 | .625 | .684 | .472 | .000 | .000 | .720 | .467 | .583 | .607 | .000 | .548 | .691 |

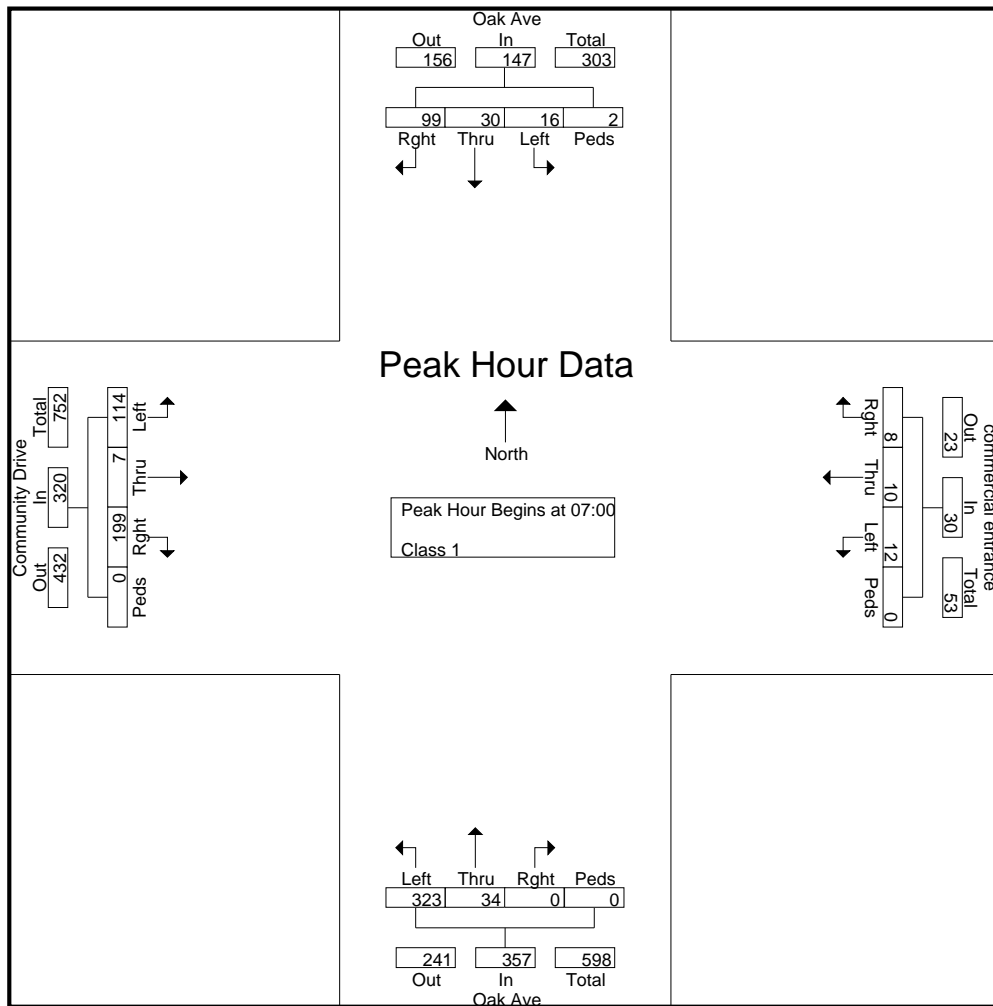

TRAFFIC DATA INC.

3268 Xenwood Ave S
St Louis Park, MN 55416

Oak Ave at Community Drive WACONIA
North of TH-5
TDI Inc
TURN MOVEMENT COUNT

File Name : 2681112 Oak & Community
Site Code : 2681112
Start Date : 2/16/2011
Page No : 4

| Start Time | Oak Ave Southbound | | | | | commercial entrance Westbound | | | | | Oak Ave Northbound | | | | | Community Drive Eastbound | | | | | Int. Total |
|--|--------------------|------|------|------|------------|-------------------------------|------|------|------|------------|--------------------|------|------|------|------------|---------------------------|------|------|------|------------|------------|
| | Left | Thru | Rght | Peds | App. Total | Left | Thru | Rght | Peds | App. Total | Left | Thru | Rght | Peds | App. Total | Left | Thru | Rght | Peds | App. Total | |
| Peak Hour Analysis From 15:00 to 18:45 - Peak 1 of 1 | | | | | | | | | | | | | | | | | | | | | |
| Peak Hour for Entire Intersection Begins at 15:00 | | | | | | | | | | | | | | | | | | | | | |
| 15:00 | 4 | 12 | 13 | 1 | 30 | 6 | 3 | 2 | 0 | 11 | 43 | 19 | 0 | 0 | 62 | 67 | 3 | 147 | 0 | 217 | 320 |
| 15:15 | 3 | 12 | 3 | 0 | 18 | 4 | 0 | 5 | 0 | 9 | 11 | 9 | 1 | 0 | 21 | 15 | 2 | 37 | 0 | 54 | 102 |
| 15:30 | 6 | 9 | 0 | 4 | 19 | 12 | 2 | 8 | 0 | 22 | 12 | 15 | 1 | 0 | 28 | 3 | 3 | 25 | 0 | 31 | 100 |
| 15:45 | 4 | 11 | 3 | 0 | 18 | 11 | 2 | 11 | 0 | 24 | 23 | 7 | 2 | 0 | 32 | 14 | 6 | 23 | 1 | 44 | 118 |
| Total Volume | 17 | 44 | 19 | 5 | 85 | 33 | 7 | 26 | 0 | 66 | 89 | 50 | 4 | 0 | 143 | 99 | 14 | 232 | 1 | 346 | 640 |
| % App. Total | 20 | 51.8 | 22.4 | 5.9 | | 50 | 10.6 | 39.4 | 0 | | 62.2 | 35 | 2.8 | 0 | | 28.6 | 4 | 67.1 | 0.3 | | |
| PHF | .708 | .917 | .365 | .313 | .708 | .688 | .583 | .591 | .000 | .688 | .517 | .658 | .500 | .000 | .577 | .369 | .583 | .395 | .250 | .399 | .500 |

