

ALLIANT ENGINEERING, INC.

733 S Marquette Ave #700, Minneapolis, MN 55402

Intersection: TH 47 & 81st Avenue
 Date: 3/21/2024
 Duration: 0600-1800

Site Code: 614
 Ref Pt: N/A
 Page No: 2 of 4

All Vehicles (Cars & Trucks) Printed

Start Time	TH 47 Southbound						81st Avenue Westbound						TH 47 Northbound						81st Avenue Eastbound						Int. Veh. Total	Int. Ped/Bike Total
	U-Turn	Left	Thru	Right	App. Total	Peds/Bikes	U-Turn	Left	Thru	Right	App. Total	Peds/Bikes	U-Turn	Left	Thru	Right	App. Total	Peds/Bikes	U-Turn	Left	Thru	Right	App. Total	Peds/Bikes		
7:15	--	6	190	24	220	2	--	18	18	8	44	--	--	22	108	10	140	2	--	10	15	26	51	--	455	4
7:30	--	7	270	34	311	--	--	17	18	6	41	--	--	27	154	16	197	--	--	7	14	25	46	--	595	--
7:45	--	15	247	19	281	2	--	26	38	11	75	--	2	41	120	30	193	2	--	7	17	23	47	2	596	6
8:00	--	15	175	25	215	--	--	14	39	14	67	--	1	36	130	25	192	1	--	8	4	19	31	--	505	1
Hour Total	--	43	882	102	1027	4	--	75	113	39	227	--	3	126	512	81	722	5	--	32	50	93	175	2	2151	11
% of App.	0.0%	4.2%	85.9%	9.9%			0.0%	33.0%	49.8%	17.2%			0.4%	17.5%	70.9%	11.2%			0.0%	18.3%	28.6%	53.1%				
% of Total	0.0%	2.0%	41.0%	4.7%	47.7%	36.4%	0.0%	3.5%	5.3%	1.8%	10.6%	0.0%	0.1%	5.9%	23.8%	3.8%	33.6%	45.5%	0.0%	1.5%	2.3%	4.3%	8.1%	18.2%		
Cars Total	--	41	860	96	997	4	--	75	110	33	218	--	3	122	488	81	694	4	--	30	47	80	157	2	2066	10
Cars % of Movement	0.0%	95.3%	97.5%	94.1%	97.1%	40.0%	0.0%	100%	97.3%	84.6%	96.0%	0.0%	100%	96.8%	95.3%	100%	96.1%	40.0%	0.0%	93.8%	94.0%	86.0%	89.7%	20.0%	96.0%	
Trucks Total	--	2	22	6	30	--	--	--	3	6	9	--	--	4	24	--	28	1	--	2	3	13	18	--	85	1
Trucks % of Movement	0.0%	4.7%	2.5%	5.9%	2.9%	0.0%	0.0%	0.0%	2.7%	15.4%	4.0%	0.0%	0.0%	3.2%	4.7%	0.0%	3.9%	#####	0.0%	6.3%	6.0%	14.0%	10.3%	0.0%	4.0%	

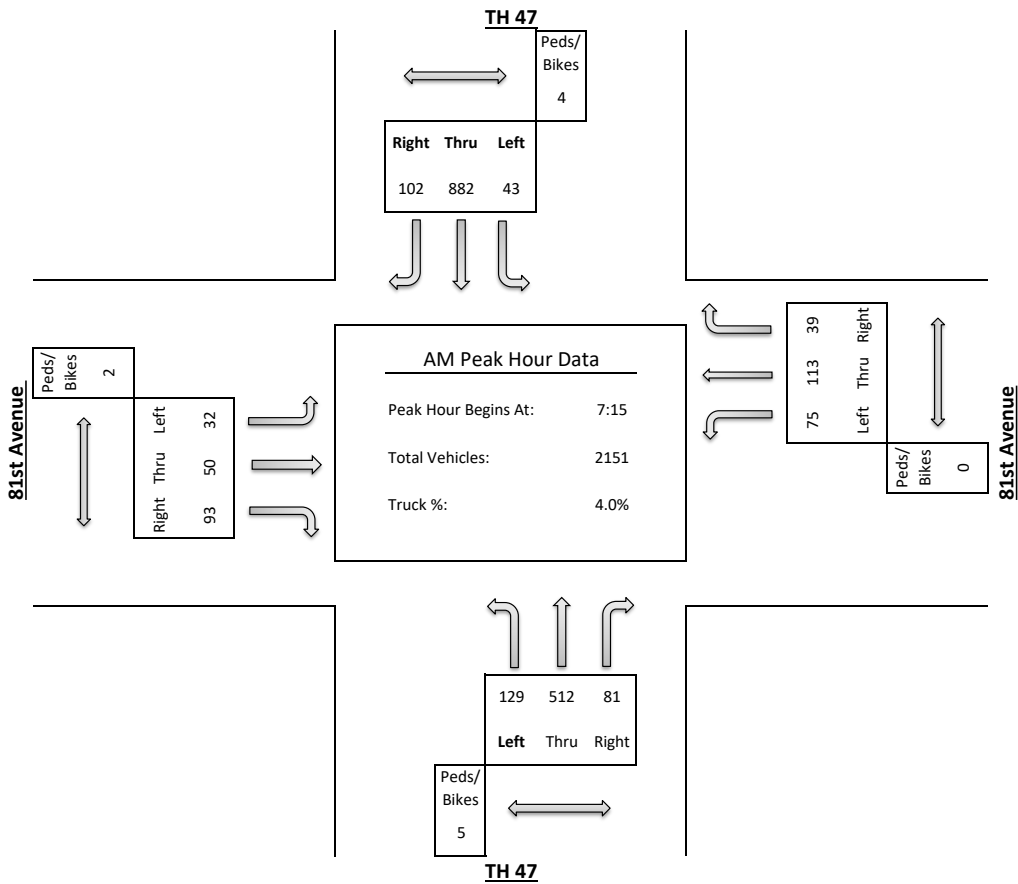

ALLIANT ENGINEERING, INC.

733 S Marquette Ave #700, Minneapolis, MN 55402

Intersection: TH 47 & 81st Avenue
 Date: 3/21/2024
 Duration: 0600-1800

Site Code: 614
 Ref Pt: N/A
 Page No: 3 of 4

All Vehicles (Cars & Trucks) Printed

Start Time	TH 47 Southbound						81st Avenue Westbound						TH 47 Northbound						81st Avenue Eastbound						Int. Veh. Total	Int. Ped/Bike Total
	U-Turn	Left	Thru	Right	App. Total	Peds/Bikes	U-Turn	Left	Thru	Right	App. Total	Peds/Bikes	U-Turn	Left	Thru	Right	App. Total	Peds/Bikes	U-Turn	Left	Thru	Right	App. Total	Peds/Bikes		
12:00	--	9	155	20	184	--	--	31	33	17	81	--	--	58	182	18	258	--	--	48	25	46	119	--	642	--
12:15	1	16	139	22	178	--	--	30	36	10	76	--	1	65	133	20	219	1	--	39	29	42	110	--	583	1
12:30	1	11	136	31	179	1	--	16	39	3	58	--	--	65	172	21	258	--	--	36	29	55	120	--	615	1
12:45	1	17	169	22	209	--	--	20	41	8	69	--	--	58	174	13	245	--	--	37	28	50	115	--	638	--
Hour Total	3	53	599	95	750	1	--	97	149	38	284	--	1	246	661	72	980	1	--	160	111	193	464	--	2478	2
% of App.	0.4%	7.1%	79.9%	12.7%			0.0%	34.2%	52.5%	13.4%			0.1%	25.1%	67.4%	7.3%			0.0%	34.5%	23.9%	41.6%				
% of Total	0.1%	2.1%	24.2%	3.8%	30.3%	50.0%	0.0%	3.9%	6.0%	1.5%	11.5%	0.0%	0.0%	9.9%	26.7%	2.9%	39.5%	50.0%	0.0%	6.5%	4.5%	7.8%	18.7%	0.0%		
Cars Total	3	50	577	88	718	1	--	97	147	36	280	--	1	235	643	72	951	1	--	147	108	180	435	--	2384	2
Cars % of Movement	100%	94.3%	96.3%	92.6%	95.7%	50.0%	0.0%	100%	98.7%	94.7%	98.6%	0.0%	100%	95.5%	97.3%	100%	97.0%	50.0%	0.0%	91.9%	97.3%	93.3%	93.8%	0.0%	96.2%	
Trucks Total	--	3	22	7	32	--	--	--	2	2	4	--	--	11	18	--	29	--	--	13	3	13	29	--	94	--
Trucks % of Movement	0.0%	5.7%	3.7%	7.4%	4.3%	--	0.0%	0.0%	1.3%	5.3%	1.4%	--	0.0%	4.5%	2.7%	0.0%	3.0%	--	0.0%	8.1%	2.7%	6.7%	6.3%	--	3.8%	

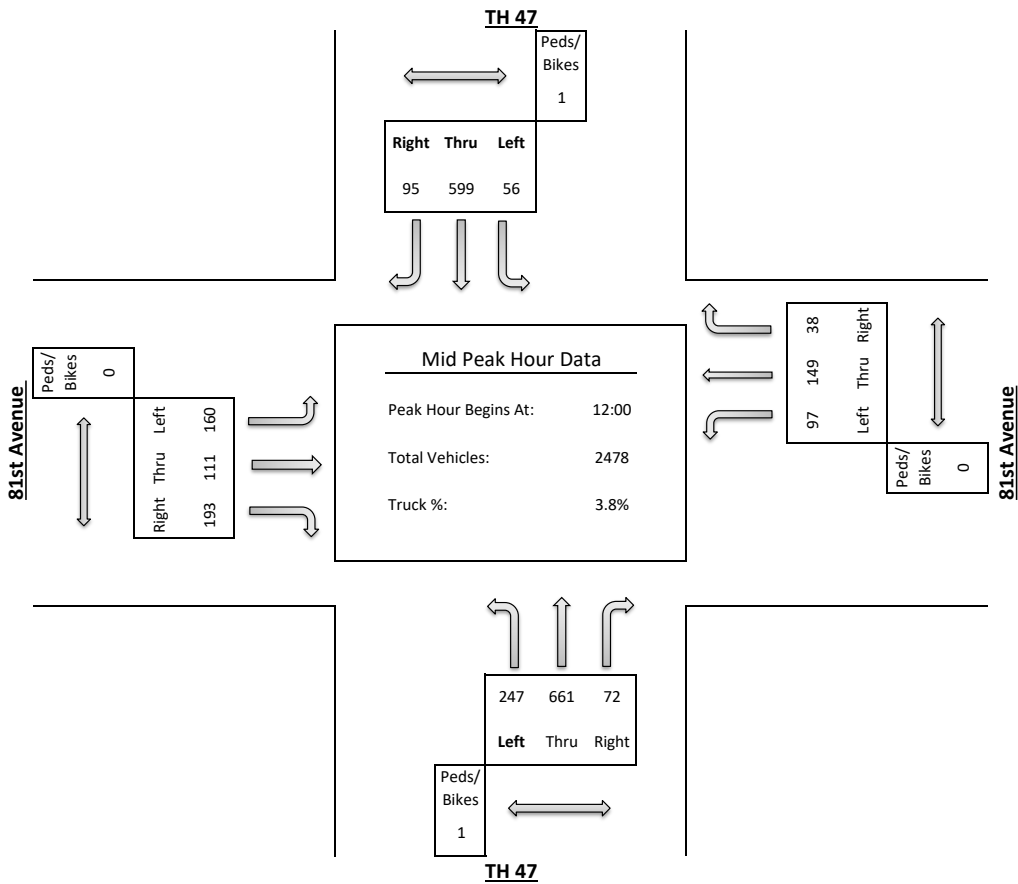

ALLIANT ENGINEERING, INC.

733 S Marquette Ave #700, Minneapolis, MN 55402

Intersection: TH 47 & 81st Avenue
 Date: 3/21/2024
 Duration: 0600-1800

Site Code: 614
 Ref Pt: N/A
 Page No: 4 of 4

All Vehicles (Cars & Trucks) Printed

Start Time	TH 47 Southbound						81st Avenue Westbound						TH 47 Northbound						81st Avenue Eastbound						Int. Veh. Total	Int. Ped/Bike Total
	U-Turn	Left	Thru	Right	App. Total	Peds/Bikes	U-Turn	Left	Thru	Right	App. Total	Peds/Bikes	U-Turn	Left	Thru	Right	App. Total	Peds/Bikes	U-Turn	Left	Thru	Right	App. Total	Peds/Bikes		
15:00	1	17	175	16	209	--	--	15	30	15	60	--	2	59	319	27	407	2	--	70	35	47	152	--	828	2
15:15	2	13	217	25	257	1	--	25	43	12	80	--	1	53	287	26	367	--	--	50	37	36	123	--	827	1
15:30	2	14	198	23	237	--	--	22	34	11	67	--	1	60	315	22	398	1	--	65	30	42	137	--	839	1
15:45	3	10	143	26	182	1	--	20	34	14	68	--	--	65	331	29	425	--	--	54	24	41	119	--	794	1
Hour Total	8	54	733	90	885	2	--	82	141	52	275	--	4	237	1252	104	1597	3	--	239	126	166	531	--	3288	5
% of App.	0.9%	6.1%	82.8%	10.2%			0.0%	29.8%	51.3%	18.9%			0.3%	14.8%	78.4%	6.5%			0.0%	45.0%	23.7%	31.3%				
% of Total	0.2%	1.6%	22.3%	2.7%	26.9%	40.0%	0.0%	2.5%	4.3%	1.6%	8.4%	0.0%	0.1%	7.2%	38.1%	3.2%	48.6%	60.0%	0.0%	7.3%	3.8%	5.0%	16.1%	0.0%		
Cars Total	8	52	710	89	859	2	--	81	137	50	268	--	4	231	1230	102	1567	3	--	232	126	159	517	--	3211	5
Cars % of Movement	100%	96.3%	96.9%	98.9%	97.1%	40.0%	0.0%	98.8%	97.2%	96.2%	97.5%	0.0%	100%	97.5%	98.2%	98.1%	98.1%	60.0%	0.0%	97.1%	100%	95.8%	97.4%	0.0%	97.7%	
Trucks Total	--	2	23	1	26	--	--	1	4	2	7	--	--	6	22	2	30	--	--	7	--	7	14	--	77	--
Trucks % of Movement	0.0%	3.7%	3.1%	1.1%	2.9%	--	0.0%	1.2%	2.8%	3.8%	2.5%	--	0.0%	2.5%	1.8%	1.9%	1.9%	--	0.0%	2.9%	0.0%	4.2%	2.6%	--	2.3%	

