

# Albeck Gerken, Inc

Transportation Engineers

Traffic Data Collection

TH-47 / University Ave at 40th Ave NE

Ref.Pt.: 005.745

Data by: Albeck Gerken Inc

TURN MOVEMENT COUNT

File Name : TH-47 at 40th Ave NE 2008

Site Code : 01828121

Start Date : 7/10/2008

Page No : 1

## Groups Printed- Unshifted

Start Time	TH-47 / University Ave Southbound				40th Ave NE Westbound				TH-47 / University Ave Northbound				40th Ave NE Eastbound				Int. Total
	Left	Thru	Right	Peds	Left	Thru	Right	Peds	Left	Thru	Right	Peds	Left	Thru	Right	Peds	
06:00	11	139	6	1	11	4	9	0	1	32	3	0	4	5	7	0	233
06:15	8	176	8	0	17	1	15	0	1	37	1	0	2	4	5	0	275
06:30	16	201	3	0	28	6	17	0	1	67	4	0	7	7	2	0	359
06:45	15	289	7	0	20	5	16	0	2	48	7	0	4	5	7	0	425
Total	50	805	24	1	76	16	57	0	5	184	15	0	17	21	21	0	1292
07:00	25	240	5	0	23	6	14	0	0	62	3	0	2	6	11	0	397
07:15	22	265	4	0	32	8	17	1	1	66	6	4	8	7	8	0	449
07:30	24	269	3	0	33	9	17	2	1	80	8	2	8	7	8	0	471
07:45	38	289	7	0	26	12	18	0	5	84	14	0	6	12	8	0	519
Total	109	1063	19	0	114	35	66	3	7	292	31	6	24	32	35	0	1836
08:00	20	190	1	0	24	10	19	1	4	68	7	0	5	6	4	0	359
08:15	21	201	3	1	25	9	15	2	1	70	11	2	5	8	10	0	384
08:30	11	131	1	1	26	5	22	0	1	77	6	0	4	12	12	1	310
08:45	27	148	6	1	15	8	12	0	0	68	12	1	6	2	4	1	311
Total	79	670	11	3	90	32	68	3	6	283	36	3	20	28	30	2	1364
*** BREAK ***																	
11:00	24	91	5	0	5	10	18	0	0	89	12	1	3	11	2	0	271
11:15	28	82	7	0	6	21	24	1	2	64	9	1	6	17	3	0	271
11:30	32	82	3	1	7	12	31	1	2	84	16	1	7	16	5	0	300
11:45	31	82	7	0	5	10	20	0	1	91	16	0	0	22	2	0	287
Total	115	337	22	1	23	53	93	2	5	328	53	3	16	66	12	0	1129
12:00	26	87	6	0	10	13	22	0	2	102	20	0	3	10	1	0	302
12:15	23	112	5	0	10	20	30	0	5	83	22	0	10	11	3	0	334
12:30	17	106	6	0	9	16	30	1	4	102	11	1	4	12	6	0	325
12:45	27	104	3	0	14	11	25	0	4	98	13	0	4	10	1	0	314
Total	93	409	20	0	43	60	107	1	15	385	66	1	21	43	11	0	1275
*** BREAK ***																	
15:00	32	95	5	2	15	13	22	0	1	137	12	0	4	17	5	0	360
15:15	21	93	4	1	14	19	25	0	1	178	11	1	9	15	3	0	395
15:30	38	125	2	1	9	14	32	0	2	202	19	0	10	9	3	0	466
15:45	23	94	6	0	20	15	28	0	8	221	31	0	14	11	4	0	475
Total	114	407	17	4	58	61	107	0	12	738	73	1	37	52	15	0	1696
16:00	27	106	4	0	19	9	25	1	4	224	21	1	14	13	6	0	474
16:15	33	121	0	0	10	7	26	1	7	254	27	2	10	13	7	0	518
16:30	31	92	3	3	19	18	23	0	10	334	30	0	10	8	2	0	583
16:45	36	108	7	0	12	22	34	0	8	297	35	0	3	19	4	0	585
Total	127	427	14	3	60	56	108	2	29	1109	113	3	37	53	19	0	2160
17:00	42	110	3	4	18	12	44	0	2	273	34	0	5	15	7	0	569
17:15	32	102	6	0	13	15	34	0	10	303	31	1	12	12	0	0	571
17:30	23	87	10	0	12	18	22	4	5	240	37	5	6	15	3	0	487
17:45	44	108	7	0	16	11	18	1	3	182	22	0	3	15	3	0	433
Total	141	407	26	4	59	56	118	5	20	998	124	6	26	57	13	0	2060
Grand Total	828	4525	153	16	523	369	724	16	99	4317	511	23	198	352	156	2	12812
Apprch %	15	81.9	2.8	0.3	32	22.6	44.4	1	2	87.2	10.3	0.5	28	49.7	22	0.3	
Total %	6.5	35.3	1.2	0.1	4.1	2.9	5.7	0.1	0.8	33.7	4	0.2	1.5	2.7	1.2	0	

# Albeck Gerken, Inc

Transportation Engineers

Traffic Data Collection

TH-47 / University Ave at 40th Ave NE

Ref.Pt.: 005.745

Data by: Albeck Gerken Inc

TURN MOVEMENT COUNT

File Name : TH-47 at 40th Ave NE 2008

Site Code : 01828121

Start Date : 7/10/2008

Page No : 2

Start Time	TH-47 / University Ave Southbound					40th Ave NE Westbound					TH-47 / University Ave Northbound					40th Ave NE Eastbound					Int. Total
	Left	Thru	Right	Peds	App. Total	Left	Thru	Right	Peds	App. Total	Left	Thru	Right	Peds	App. Total	Left	Thru	Right	Peds	App. Total	
Peak Hour Analysis From 06:00 to 08:45 - Peak 1 of 1																					
Peak Hour for Entire Intersection Begins at 07:00																					
07:00	25	240	5	0	270	23	6	14	0	43	0	62	3	0	65	2	6	11	0	19	397
07:15	22	265	4	0	291	32	8	17	1	58	1	66	6	4	77	8	7	8	0	23	449
07:30	24	269	3	0	296	33	9	17	2	61	1	80	8	2	91	8	7	8	0	23	471
07:45	38	289	7	0	334	26	12	18	0	56	5	84	14	0	103	6	12	8	0	26	519
Total Volume	109	1063	19	0	1191	114	35	66	3	218	7	292	31	6	336	24	32	35	0	91	1836
% App. Total	9.2	89.3	1.6	0		52.3	16.1	30.3	1.4		2.1	86.9	9.2	1.8		26.4	35.2	38.5	0		
PHF	.717	.920	.679	.000	.891	.864	.729	.917	.375	.893	.350	.869	.554	.375	.816	.750	.667	.795	.000	.875	.884

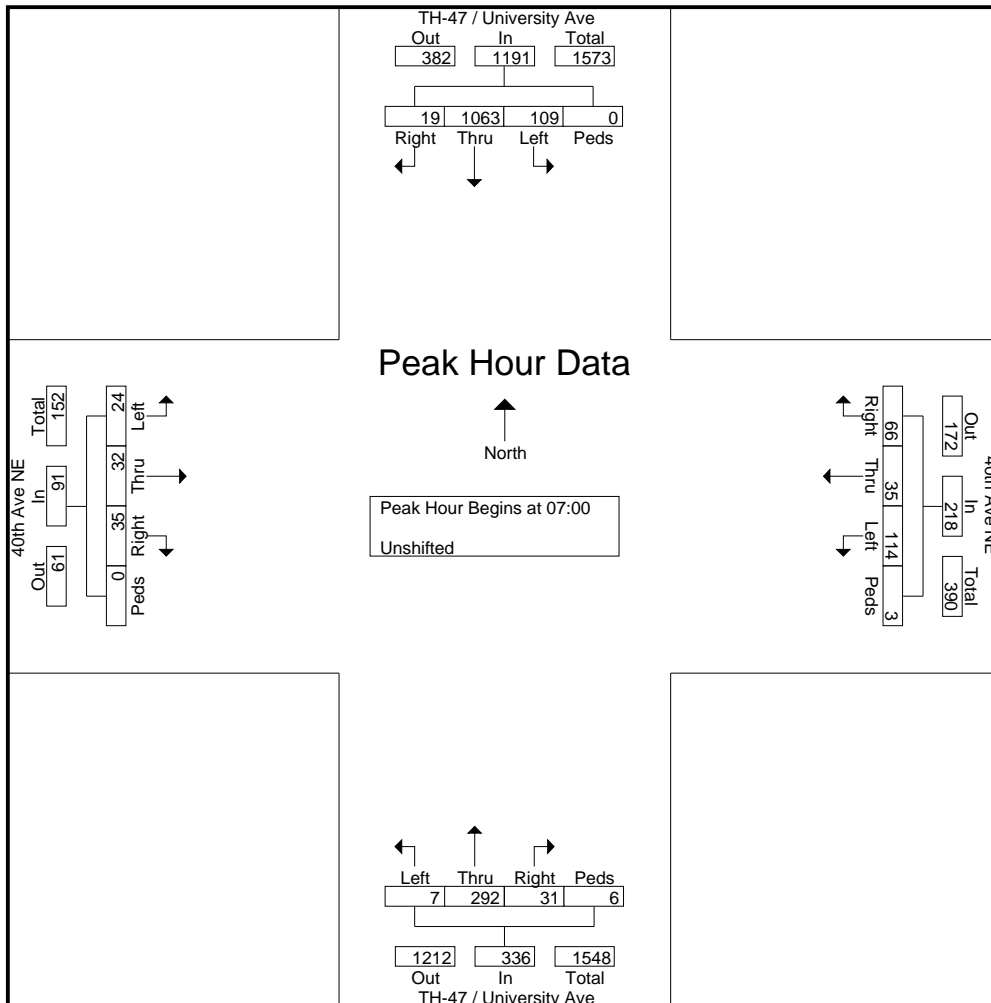

# Albeck Gerken, Inc

Transportation Engineers

Traffic Data Collection

TH-47 / University Ave at 40th Ave NE

Ref.Pt.: 005.745

Data by: Albeck Gerken Inc

TURN MOVEMENT COUNT

File Name : TH-47 at 40th Ave NE 2008

Site Code : 01828121

Start Date : 7/10/2008

Page No : 3

Start Time	TH-47 / University Ave Southbound					40th Ave NE Westbound					TH-47 / University Ave Northbound					40th Ave NE Eastbound					Int. Total
	Left	Thru	Right	Peds	App. Total	Left	Thru	Right	Peds	App. Total	Left	Thru	Right	Peds	App. Total	Left	Thru	Right	Peds	App. Total	
Peak Hour Analysis From 15:00 to 17:45 - Peak 1 of 1																					
Peak Hour for Entire Intersection Begins at 16:30																					
16:30	31	92	3	3	129	19	18	23	0	60	10	334	30	0	374	10	8	2	0	20	583
16:45	36	108	7	0	151	12	22	34	0	68	8	297	35	0	340	3	19	4	0	26	585
17:00	42	110	3	4	159	18	12	44	0	74	2	273	34	0	309	5	15	7	0	27	569
17:15	32	102	6	0	140	13	15	34	0	62	10	303	31	1	345	12	12	0	0	24	571
Total Volume	141	412	19	7	579	62	67	135	0	264	30	1207	130	1	1368	30	54	13	0	97	2308
% App. Total	24.4	71.2	3.3	1.2		23.5	25.4	51.1	0		2.2	88.2	9.5	0.1		30.9	55.7	13.4	0		
PHF	.839	.936	.679	.438	.910	.816	.761	.767	.000	.892	.750	.903	.929	.250	.914	.625	.711	.464	.000	.898	.986

