

MN Dept of Transportation

TRAFFIC DATA COLLECTION - Metro

TH-41 at 4th Street CHASKA
 Ref.Pt.: 001.883
 video AL
 TURN MOVEMENT COUNT - Sunday

File Name : TH-41 at 4th St CHASKA Sun 2015
 Site Code :
 Start Date : 6/28/2015
 Page No : 1

Groups Printed- Cars +

Start Time	TH-41 SB Southbound				4th St WB Westbound				TH-41 NB Northbound				4th St EB Eastbound				Int. Total
	Left	Thru	Right	Peds	Left	Thru	Right	Peds	Left	Thru	Right	Peds	Left	Thru	Right	Peds	
06:00	1	30	0	0	3	0	4	0	0	20	6	0	0	0	0	0	64
06:15	0	37	0	0	0	1	0	0	1	28	3	0	1	0	0	0	71
06:30	0	39	0	0	3	0	2	0	0	34	1	0	0	1	0	0	80
06:45	1	38	1	0	0	0	1	0	0	38	0	0	0	0	2	0	81
Total	2	144	1	0	6	1	7	0	1	120	10	0	1	1	2	0	296
07:00	4	45	0	0	3	0	1	0	0	35	0	0	0	0	3	0	91
07:15	2	43	2	0	1	1	1	0	0	45	1	1	0	0	0	1	98
07:30	5	53	0	0	3	1	0	0	1	37	3	0	1	1	2	0	107
07:45	8	68	3	0	3	1	1	0	2	49	3	0	0	3	0	0	141
Total	19	209	5	0	10	3	3	0	3	166	7	1	1	4	5	1	437
08:00	6	47	1	0	3	0	1	0	2	51	3	0	0	2	1	0	117
08:15	16	53	0	0	3	1	3	0	0	48	7	0	0	0	1	0	132
08:30	6	69	1	0	6	1	3	0	7	42	6	0	0	3	1	0	145
08:45	4	55	2	0	3	0	9	0	2	59	2	0	0	0	2	0	138
Total	32	224	4	0	15	2	16	0	11	200	18	0	0	5	5	0	532
09:00	3	71	0	0	7	1	4	0	0	81	5	0	3	4	0	0	179
09:15	10	102	3	0	5	1	7	0	2	87	5	2	2	8	1	0	235
09:30	15	113	1	0	7	5	5	0	1	99	7	1	1	2	1	0	258
09:45	24	154	4	0	16	7	15	0	2	98	4	1	0	4	1	0	330
Total	52	440	8	0	35	14	31	0	5	365	21	4	6	18	3	0	1002
10:00	10	152	3	0	5	1	7	0	2	88	7	1	2	2	3	0	283
10:15	3	132	1	0	17	2	3	2	2	110	1	0	1	2	2	0	278
10:30	10	160	0	0	11	4	6	0	3	118	6	0	1	3	1	0	323
10:45	4	143	0	1	9	5	13	1	4	127	5	0	5	1	4	0	322
Total	27	587	4	1	42	12	29	3	11	443	19	1	9	8	10	0	1206
11:00	7	131	2	0	8	2	7	1	0	116	3	0	6	2	4	0	289
11:15	6	187	0	0	24	3	33	1	5	138	4	0	2	1	3	0	407
11:30	6	167	5	0	12	7	12	0	3	161	5	1	6	4	3	0	392
11:45	6	153	1	3	15	3	2	0	7	134	5	0	4	6	5	2	346
Total	25	638	8	3	59	15	54	2	15	549	17	1	18	13	15	2	1434
12:00	11	161	3	0	10	5	7	0	3	149	7	0	5	3	2	0	366
12:15	3	173	6	0	8	2	5	2	2	172	4	0	3	1	1	0	382
12:30	5	177	3	0	4	4	2	2	2	160	8	4	3	4	2	0	380
12:45	10	192	3	1	12	1	3	1	6	157	6	0	2	3	2	0	399
Total	29	703	15	1	34	12	17	5	13	638	25	4	13	11	7	0	1527
13:00	8	161	2	1	5	5	10	1	2	166	7	0	2	1	2	0	373
13:15	7	186	4	2	6	2	6	2	5	149	8	0	1	3	2	0	383
13:30	8	178	4	0	8	2	4	0	2	165	12	0	5	2	7	0	397
13:45	11	170	4	1	15	4	8	0	5	175	11	5	3	4	4	0	420
Total	34	695	14	4	34	13	28	3	14	655	38	5	11	10	15	0	1573
14:00	2	163	1	0	13	1	5	0	4	156	8	0	5	3	1	0	362
14:15	6	153	3	0	11	1	7	0	7	159	10	1	6	2	5	0	371
14:30	5	133	2	1	9	3	2	0	4	154	9	0	3	2	4	0	331
14:45	3	147	6	1	11	3	3	0	4	134	8	2	5	1	1	0	329
Total	16	596	12	2	44	8	17	0	19	603	35	3	19	8	11	0	1393
15:00	4	153	1	0	8	4	13	0	6	196	7	0	2	5	0	0	399
15:15	7	182	6	0	6	1	3	0	6	153	8	0	2	7	2	0	383
15:30	6	157	4	0	7	3	5	0	3	179	12	0	3	5	3	0	387
15:45	6	148	5	1	8	5	6	0	4	177	8	0	2	4	2	0	376
Total	23	640	16	1	29	13	27	0	19	705	35	0	9	21	7	0	1545

MN Dept of Transportation

TRAFFIC DATA COLLECTION - Metro

TH-41 at 4th Street CHASKA
 Ref.Pt.: 001.883
 video AL
 TURN MOVEMENT COUNT - Sunday

File Name : TH-41 at 4th St CHASKA Sun 2015
 Site Code :
 Start Date : 6/28/2015
 Page No : 2

Groups Printed- Cars +

Start Time	TH-41 SB Southbound				4th St WB Westbound				TH-41 NB Northbound				4th St EB Eastbound				Int. Total
	Left	Thru	Right	Peds	Left	Thru	Right	Peds	Left	Thru	Right	Peds	Left	Thru	Right	Peds	
16:00	14	166	4	0	12	5	7	0	5	154	7	1	6	2	5	1	389
16:15	6	184	6	1	7	6	3	2	1	226	10	0	5	5	3	0	465
16:30	6	165	1	1	7	4	4	0	6	213	7	0	6	3	0	0	423
16:45	5	155	5	0	9	1	7	0	1	188	15	0	3	3	4	0	396
Total	31	670	16	2	35	16	21	2	13	781	39	1	20	13	12	1	1673
17:00	2	154	7	0	7	3	12	0	6	170	8	1	5	4	5	0	384
17:15	1	148	2	0	7	1	4	0	6	173	5	0	1	1	2	0	351
17:30	2	143	7	0	8	3	4	0	4	164	7	0	4	3	3	0	352
17:45	2	125	3	0	6	5	5	0	5	176	7	0	2	4	4	0	344
Total	7	570	19	0	28	12	25	0	21	683	27	1	12	12	14	0	1431
Grand Total	297	6116	122	14	371	121	275	15	145	5908	291	21	119	124	106	4	14049
Apprch %	4.5	93.4	1.9	0.2	47.4	15.5	35.2	1.9	2.3	92.8	4.6	0.3	33.7	35.1	30	1.1	
Total %	2.1	43.5	0.9	0.1	2.6	0.9	2	0.1	1	42.1	2.1	0.1	0.8	0.9	0.8	0	

MN Dept of Transportation

TRAFFIC DATA COLLECTION - Metro

TH-41 at 4th Street CHASKA
 Ref.Pt.: 001.883
 video AL
 TURN MOVEMENT COUNT - Sunday

File Name : TH-41 at 4th St CHASKA Sun 2015
 Site Code :
 Start Date : 6/28/2015
 Page No : 3

Start Time	TH-41 SB Southbound					4th St WB Westbound					TH-41 NB Northbound					4th St EB Eastbound					Int. Total
	Left	Thru	Right	Peds	App. Total	Left	Thru	Right	Peds	App. Total	Left	Thru	Right	Peds	App. Total	Left	Thru	Right	Peds	App. Total	
Peak Hour Analysis From 06:00 to 08:45 - Peak 1 of 1																					
Peak Hour for Entire Intersection Begins at 07:45																					
07:45	8	68	3	0	79	3	1	1	0	5	2	49	3	0	54	0	3	0	0	3	141
08:00	6	47	1	0	54	3	0	1	0	4	2	51	3	0	56	0	2	1	0	3	117
08:15	16	53	0	0	69	3	1	3	0	7	0	48	7	0	55	0	0	1	0	1	132
08:30	6	69	1	0	76	6	1	3	0	10	7	42	6	0	55	0	3	1	0	4	145
Total Volume	36	237	5	0	278	15	3	8	0	26	11	190	19	0	220	0	8	3	0	11	535
% App. Total	12.9	85.3	1.8	0		57.7	11.5	30.8	0		5	86.4	8.6	0		0	72.7	27.3	0		
PHF	.563	.859	.417	.000	.880	.625	.750	.667	.000	.650	.393	.931	.679	.000	.982	.000	.667	.750	.000	.688	.922

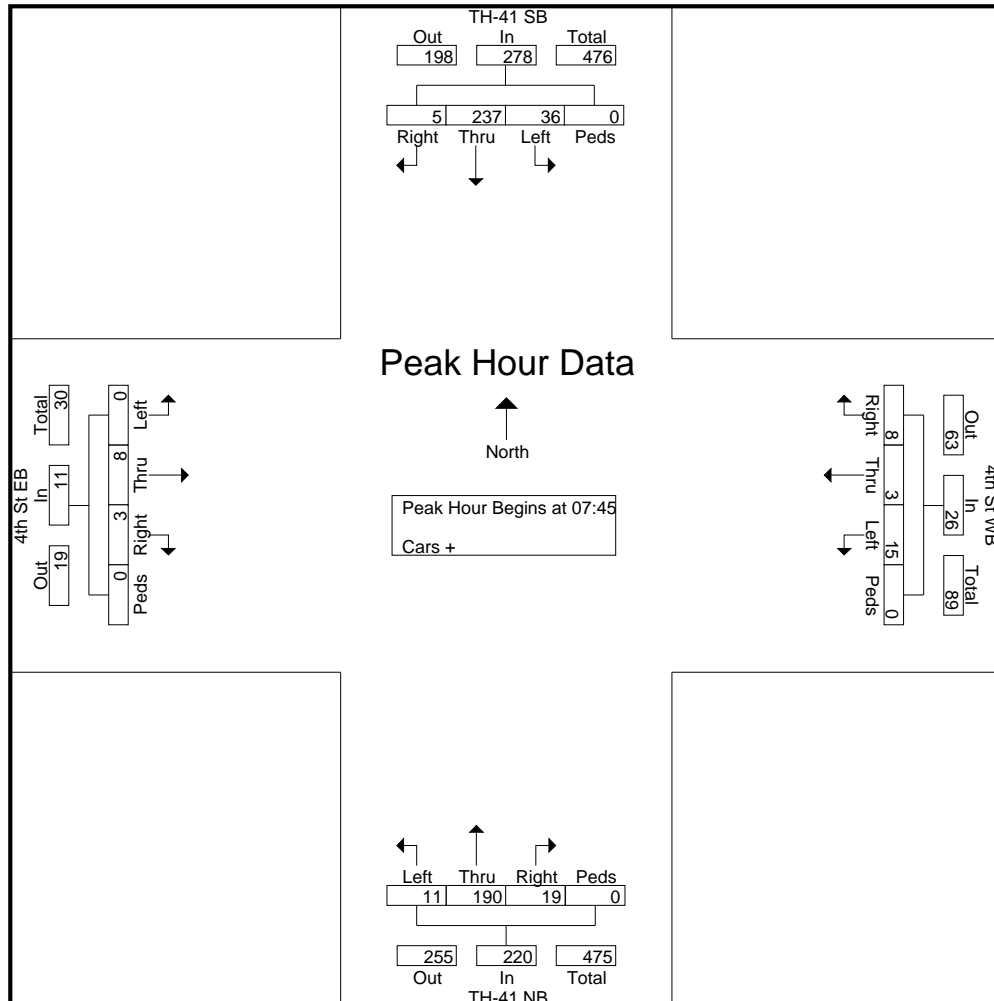

MN Dept of Transportation

TRAFFIC DATA COLLECTION - Metro

TH-41 at 4th Street CHASKA
 Ref.Pt.: 001.883
 video AL
 TURN MOVEMENT COUNT - Sunday

File Name : TH-41 at 4th St CHASKA Sun 2015
 Site Code :
 Start Date : 6/28/2015
 Page No : 4

Start Time	TH-41 SB Southbound					4th St WB Westbound					TH-41 NB Northbound					4th St EB Eastbound					Int. Total
	Left	Thru	Right	Peds	App. Total	Left	Thru	Right	Peds	App. Total	Left	Thru	Right	Peds	App. Total	Left	Thru	Right	Peds	App. Total	
Peak Hour Analysis From 15:00 to 17:45 - Peak 1 of 1																					
Peak Hour for Entire Intersection Begins at 16:00																					
16:00	14	166	4	0	184	12	5	7	0	24	5	154	7	1	167	6	2	5	1	14	389
16:15	6	184	6	1	197	7	6	3	2	18	1	226	10	0	237	5	5	3	0	13	465
16:30	6	165	1	1	173	7	4	4	0	15	6	213	7	0	226	6	3	0	0	9	423
16:45	5	155	5	0	165	9	1	7	0	17	1	188	15	0	204	3	3	4	0	10	396
Total Volume	31	670	16	2	719	35	16	21	2	74	13	781	39	1	834	20	13	12	1	46	1673
% App. Total	4.3	93.2	2.2	0.3		47.3	21.6	28.4	2.7		1.6	93.6	4.7	0.1		43.5	28.3	26.1	2.2		
PHF	.554	.910	.667	.500	.912	.729	.667	.750	.250	.771	.542	.864	.650	.250	.880	.833	.650	.600	.250	.821	.899

