

Alliant Engineering, Inc

233 Park Ave Suite 300

Minneapolis, MN 55415

--TRAFFIC DATA --

TH-36 at Osgood Avenue

Ref.Pt.: 19.74

data by : Alliant Inc.

TURN MOVEMENT COUNT

File Name : 307_TH 36 & Osgood Ave

Site Code : 307

Start Date : 11/14/2017

Page No : 1

Groups Printed- Vehicles - Trucks

| Start Time | Osgood Ave From North | | | | TH 36 From East | | | | Osgood Ave From South | | | | TH 36 From West | | | | Int. Total |
|---------------|-----------------------|------|------|------|-----------------|------|------|------|-----------------------|------|------|------|-----------------|------|------|------|------------|
| | Other | Left | Thru | Rght | Other | Left | Thru | Rght | Other | Left | Thru | Rght | Other | Left | Thru | Rght | |
| 06:00 AM | 0 | 1 | 5 | 17 | 0 | 28 | 251 | 12 | 0 | 35 | 8 | 11 | 0 | 0 | 72 | 23 | 463 |
| 06:15 AM | 1 | 3 | 18 | 13 | 0 | 43 | 335 | 6 | 0 | 31 | 16 | 9 | 0 | 1 | 63 | 39 | 578 |
| 06:30 AM | 0 | 2 | 29 | 7 | 0 | 53 | 312 | 13 | 35 | 29 | 14 | 2 | 0 | 5 | 77 | 32 | 610 |
| 06:45 AM | 0 | 2 | 34 | 22 | 0 | 69 | 382 | 22 | 0 | 59 | 25 | 7 | 0 | 1 | 110 | 26 | 759 |
| Total | 1 | 8 | 86 | 59 | 0 | 193 | 1280 | 53 | 35 | 154 | 63 | 29 | 0 | 7 | 322 | 120 | 2410 |
| 07:00 AM | 0 | 18 | 28 | 45 | 0 | 46 | 383 | 16 | 0 | 70 | 27 | 2 | 0 | 0 | 126 | 37 | 798 |
| 07:15 AM | 0 | 0 | 39 | 28 | 0 | 52 | 383 | 44 | 0 | 75 | 37 | 5 | 0 | 1 | 150 | 37 | 851 |
| 07:30 AM | 0 | 7 | 50 | 37 | 1 | 63 | 331 | 21 | 0 | 69 | 47 | 1 | 0 | 9 | 155 | 47 | 838 |
| 07:45 AM | 0 | 13 | 43 | 27 | 0 | 84 | 336 | 27 | 0 | 52 | 67 | 1 | 0 | 56 | 146 | 37 | 889 |
| Total | 0 | 38 | 160 | 137 | 1 | 245 | 1433 | 108 | 0 | 266 | 178 | 9 | 0 | 66 | 577 | 158 | 3376 |
| 08:00 AM | 0 | 7 | 42 | 26 | 0 | 37 | 250 | 15 | 0 | 47 | 44 | 2 | 0 | 59 | 138 | 44 | 711 |
| 08:15 AM | 0 | 11 | 38 | 27 | 0 | 38 | 277 | 20 | 0 | 61 | 32 | 2 | 0 | 49 | 129 | 46 | 730 |
| 08:30 AM | 0 | 8 | 35 | 34 | 0 | 24 | 248 | 14 | 0 | 49 | 36 | 5 | 0 | 48 | 141 | 36 | 678 |
| 08:45 AM | 0 | 6 | 45 | 26 | 0 | 42 | 230 | 18 | 0 | 56 | 48 | 1 | 0 | 53 | 137 | 41 | 703 |
| Total | 0 | 32 | 160 | 113 | 0 | 141 | 1005 | 67 | 0 | 213 | 160 | 10 | 0 | 209 | 545 | 167 | 2822 |
| 09:00 AM | 0 | 10 | 42 | 42 | 0 | 31 | 180 | 8 | 0 | 51 | 33 | 6 | 0 | 56 | 124 | 50 | 633 |
| 09:15 AM | 0 | 7 | 23 | 44 | 0 | 19 | 186 | 8 | 0 | 71 | 29 | 1 | 0 | 41 | 105 | 47 | 581 |
| *** BREAK *** | | | | | | | | | | | | | | | | | |
| Total | 0 | 17 | 65 | 86 | 0 | 50 | 366 | 16 | 0 | 122 | 62 | 7 | 0 | 97 | 229 | 97 | 1214 |
| *** BREAK *** | | | | | | | | | | | | | | | | | |
| 10:30 AM | 0 | 9 | 16 | 29 | 0 | 6 | 160 | 8 | 0 | 51 | 19 | 3 | 1 | 32 | 110 | 30 | 474 |
| 10:45 AM | 0 | 10 | 34 | 51 | 0 | 16 | 176 | 14 | 0 | 36 | 28 | 7 | 1 | 55 | 134 | 35 | 597 |
| Total | 0 | 19 | 50 | 80 | 0 | 22 | 336 | 22 | 0 | 87 | 47 | 10 | 2 | 87 | 244 | 65 | 1071 |
| 11:00 AM | 0 | 17 | 32 | 47 | 0 | 28 | 183 | 3 | 0 | 48 | 28 | 9 | 1 | 40 | 163 | 34 | 633 |
| 11:15 AM | 0 | 12 | 26 | 58 | 0 | 37 | 196 | 14 | 0 | 39 | 23 | 4 | 0 | 46 | 157 | 36 | 648 |
| 11:30 AM | 0 | 18 | 38 | 39 | 0 | 18 | 176 | 11 | 0 | 46 | 21 | 4 | 0 | 39 | 173 | 35 | 618 |
| 11:45 AM | 0 | 15 | 49 | 35 | 0 | 25 | 158 | 11 | 0 | 37 | 28 | 3 | 0 | 38 | 204 | 37 | 640 |
| Total | 0 | 62 | 145 | 179 | 0 | 108 | 713 | 39 | 0 | 170 | 100 | 20 | 1 | 163 | 697 | 142 | 2539 |
| 12:00 PM | 0 | 5 | 55 | 64 | 0 | 25 | 167 | 8 | 0 | 47 | 28 | 2 | 0 | 51 | 179 | 37 | 668 |
| 12:15 PM | 0 | 16 | 49 | 37 | 0 | 23 | 156 | 7 | 0 | 42 | 35 | 6 | 0 | 60 | 158 | 36 | 625 |
| 12:30 PM | 0 | 13 | 66 | 59 | 0 | 21 | 130 | 9 | 0 | 31 | 51 | 3 | 0 | 68 | 174 | 49 | 674 |
| 12:45 PM | 0 | 11 | 27 | 38 | 0 | 17 | 175 | 4 | 0 | 41 | 45 | 8 | 1 | 68 | 167 | 54 | 656 |
| Total | 0 | 45 | 197 | 198 | 0 | 86 | 628 | 28 | 0 | 161 | 159 | 19 | 1 | 247 | 678 | 176 | 2623 |
| 01:00 PM | 0 | 10 | 24 | 43 | 0 | 11 | 113 | 10 | 0 | 29 | 27 | 3 | 0 | 48 | 231 | 56 | 605 |
| 01:15 PM | 0 | 14 | 32 | 21 | 0 | 17 | 150 | 12 | 0 | 46 | 19 | 1 | 0 | 38 | 198 | 46 | 594 |
| *** BREAK *** | | | | | | | | | | | | | | | | | |
| Total | 0 | 24 | 56 | 64 | 0 | 28 | 263 | 22 | 0 | 75 | 46 | 4 | 0 | 86 | 429 | 102 | 1199 |
| *** BREAK *** | | | | | | | | | | | | | | | | | |
| 02:30 PM | 0 | 25 | 59 | 47 | 0 | 17 | 160 | 10 | 0 | 60 | 24 | 1 | 0 | 48 | 243 | 50 | 744 |
| 02:45 PM | 0 | 11 | 22 | 24 | 0 | 13 | 225 | 10 | 0 | 34 | 18 | 0 | 0 | 33 | 287 | 51 | 728 |
| Total | 0 | 36 | 81 | 71 | 0 | 30 | 385 | 20 | 0 | 94 | 42 | 1 | 0 | 81 | 530 | 101 | 1472 |
| 03:00 PM | 0 | 35 | 49 | 59 | 0 | 18 | 164 | 8 | 0 | 59 | 32 | 3 | 1 | 73 | 236 | 50 | 787 |
| 03:15 PM | 1 | 6 | 26 | 51 | 0 | 19 | 143 | 8 | 0 | 75 | 36 | 5 | 0 | 67 | 287 | 78 | 802 |
| 03:30 PM | 0 | 25 | 44 | 44 | 0 | 28 | 213 | 20 | 0 | 78 | 51 | 4 | 0 | 64 | 311 | 76 | 958 |
| 03:45 PM | 0 | 17 | 93 | 64 | 0 | 19 | 185 | 11 | 0 | 56 | 61 | 20 | 0 | 74 | 277 | 63 | 940 |
| Total | 1 | 83 | 212 | 218 | 0 | 84 | 705 | 47 | 0 | 268 | 180 | 32 | 1 | 278 | 1111 | 267 | 3487 |
| 04:00 PM | 0 | 26 | 72 | 55 | 0 | 13 | 168 | 11 | 0 | 64 | 31 | 1 | 0 | 75 | 322 | 77 | 915 |
| 04:15 PM | 0 | 27 | 89 | 80 | 0 | 12 | 234 | 6 | 0 | 53 | 48 | 1 | 0 | 73 | 332 | 74 | 1029 |
| 04:30 PM | 0 | 71 | 152 | 110 | 0 | 16 | 197 | 7 | 0 | 71 | 41 | 0 | 0 | 65 | 310 | 74 | 1114 |
| 04:45 PM | 0 | 28 | 80 | 57 | 0 | 30 | 265 | 10 | 0 | 59 | 41 | 9 | 0 | 51 | 371 | 68 | 1069 |
| Total | 0 | 152 | 393 | 302 | 0 | 71 | 864 | 34 | 0 | 247 | 161 | 11 | 0 | 264 | 1335 | 293 | 4127 |

Alliant Engineering, Inc

233 Park Ave Suite 300

Minneapolis, MN 55415

--TRAFFIC DATA --

TH-36 at Osgood Avenue
 Ref.Pt.: 19.74
 data by : Alliant Inc.
 TURN MOVEMENT COUNT

File Name : 307_TH 36 & Osgood Ave
 Site Code : 307
 Start Date : 11/14/2017
 Page No : 2

Groups Printed- Vehicles - Trucks

| Start Time | Osgood Ave From North | | | | TH 36 From East | | | | Osgood Ave From South | | | | TH 36 From West | | | | Int. Total |
|-------------|--------------------------|------|------|------|--------------------|------|------|------|--------------------------|------|------|------|--------------------|------|------|------|------------|
| | Other | Left | Thru | Rght | Other | Left | Thru | Rght | Other | Left | Thru | Rght | Other | Left | Thru | Rght | |
| 05:00 PM | 0 | 28 | 60 | 34 | 0 | 22 | 241 | 8 | 0 | 63 | 34 | 7 | 0 | 93 | 390 | 92 | 1072 |
| 05:15 PM | 0 | 17 | 68 | 38 | 0 | 22 | 186 | 10 | 0 | 74 | 57 | 0 | 0 | 86 | 305 | 75 | 938 |
| 05:30 PM | 0 | 17 | 40 | 29 | 0 | 19 | 203 | 8 | 0 | 54 | 32 | 2 | 0 | 81 | 269 | 79 | 833 |
| 05:45 PM | 0 | 9 | 44 | 28 | 0 | 27 | 206 | 7 | 0 | 41 | 9 | 0 | 0 | 81 | 285 | 55 | 792 |
| Total | 0 | 71 | 212 | 129 | 0 | 90 | 836 | 33 | 0 | 232 | 132 | 9 | 0 | 341 | 1249 | 301 | 3635 |
| Grand Total | 2 | 587 | 1817 | 1636 | 1 | 1148 | 8814 | 489 | 35 | 2089 | 1330 | 161 | 5 | 1926 | 7946 | 1989 | 29975 |
| Apprch % | 0 | 14.5 | 45 | 40.5 | 0 | 11 | 84.3 | 4.7 | 1 | 57.8 | 36.8 | 4.5 | 0 | 16.2 | 67 | 16.8 | |
| Total % | 0 | 2 | 6.1 | 5.5 | 0 | 3.8 | 29.4 | 1.6 | 0.1 | 7 | 4.4 | 0.5 | 0 | 6.4 | 26.5 | 6.6 | |
| Vehicles | 2 | 579 | 1788 | 1584 | 1 | 1103 | 8354 | 475 | 32 | 2013 | 1305 | 146 | 5 | 1869 | 7551 | 1881 | 28688 |
| % Vehicles | 100 | 98.6 | 98.4 | 96.8 | 100 | 96.1 | 94.8 | 97.1 | 91.4 | 96.4 | 98.1 | 90.7 | 100 | 97 | 95 | 94.6 | 95.7 |
| Trucks | 0 | 8 | 29 | 52 | 0 | 45 | 460 | 14 | 3 | 76 | 25 | 15 | 0 | 57 | 395 | 108 | 1287 |
| % Trucks | 0 | 1.4 | 1.6 | 3.2 | 0 | 3.9 | 5.2 | 2.9 | 8.6 | 3.6 | 1.9 | 9.3 | 0 | 3 | 5 | 5.4 | 4.3 |

Alliant Engineering, Inc

233 Park Ave Suite 300
 Minneapolis, MN 55415
 --TRAFFIC DATA --

TH-36 at Osgood Avenue
 Ref.Pt.: 19.74
 data by : Alliant Inc.
 TURN MOVEMENT COUNT

File Name : 307_TH 36 & Osgood Ave
 Site Code : 307
 Start Date : 11/14/2017
 Page No : 3

| Start Time | Osgood Ave From North | | | | | TH 36 From East | | | | | Osgood Ave From South | | | | | TH 36 From West | | | | | Int. Total |
|--|-----------------------|------|------|------|------------|-----------------|------|------|------|------------|-----------------------|------|------|------|------------|-----------------|------|------|------|------------|------------|
| | Other | Left | Thru | Rght | App. Total | Other | Left | Thru | Rght | App. Total | Other | Left | Thru | Rght | App. Total | Other | Left | Thru | Rght | App. Total | |
| Peak Hour Analysis From 06:00 AM to 11:45 AM - Peak 1 of 1 | | | | | | | | | | | | | | | | | | | | | |
| Peak Hour for Entire Intersection Begins at 07:00 AM | | | | | | | | | | | | | | | | | | | | | |
| 07:00 AM | 0 | 18 | 28 | 45 | 91 | 0 | 46 | 383 | 16 | 445 | 0 | 70 | 27 | 2 | 99 | 0 | 0 | 126 | 37 | 163 | 798 |
| 07:15 AM | 0 | 0 | 39 | 28 | 67 | 0 | 52 | 383 | 44 | 479 | 0 | 75 | 37 | 5 | 117 | 0 | 1 | 150 | 37 | 188 | 851 |
| 07:30 AM | 0 | 7 | 50 | 37 | 94 | 1 | 63 | 331 | 21 | 416 | 0 | 69 | 47 | 1 | 117 | 0 | 9 | 155 | 47 | 211 | 838 |
| 07:45 AM | 0 | 13 | 43 | 27 | 83 | 0 | 84 | 336 | 27 | 447 | 0 | 52 | 67 | 1 | 120 | 0 | 56 | 146 | 37 | 239 | 889 |
| Total Volume | 0 | 38 | 160 | 137 | 335 | 1 | 245 | 1433 | 108 | 1787 | 0 | 266 | 178 | 9 | 453 | 0 | 66 | 577 | 158 | 801 | 3376 |
| % App. Total | 0 | 11.3 | 47.8 | 40.9 | | 0.1 | 13.7 | 80.2 | 6 | | 0 | 58.7 | 39.3 | 2 | | 0 | 8.2 | 72 | 19.7 | | |
| PHF | .000 | .528 | .800 | .761 | .891 | .250 | .729 | .935 | .614 | .933 | .000 | .887 | .664 | .450 | .944 | .000 | .295 | .931 | .840 | .838 | .949 |

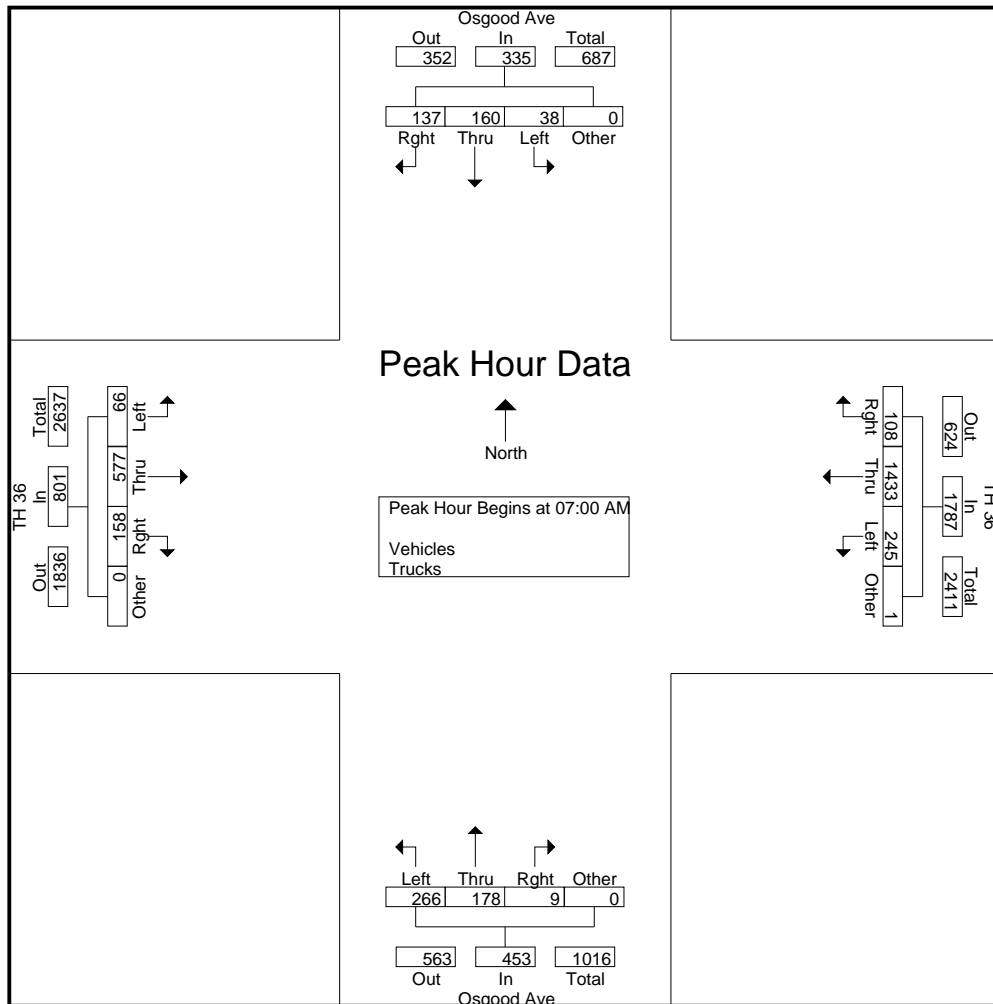

Alliant Engineering, Inc

233 Park Ave Suite 300
 Minneapolis, MN 55415
 --TRAFFIC DATA --

TH-36 at Osgood Avenue
 Ref.Pt.: 19.74
 data by : Alliant Inc.
 TURN MOVEMENT COUNT

File Name : 307_TH 36 & Osgood Ave
 Site Code : 307
 Start Date : 11/14/2017
 Page No : 4

| Start Time | Osgood Ave From North | | | | | TH 36 From East | | | | | Osgood Ave From South | | | | | TH 36 From West | | | | | Int. Total |
|--|-----------------------|------|------|------|------------|-----------------|------|------|------|------------|-----------------------|------|------|------|------------|-----------------|------|------|------|------------|------------|
| | Other | Left | Thru | Rght | App. Total | Other | Left | Thru | Rght | App. Total | Other | Left | Thru | Rght | App. Total | Other | Left | Thru | Rght | App. Total | |
| Peak Hour Analysis From 12:00 PM to 05:45 PM - Peak 1 of 1 | | | | | | | | | | | | | | | | | | | | | |
| Peak Hour for Entire Intersection Begins at 04:15 PM | | | | | | | | | | | | | | | | | | | | | |
| 04:15 PM | 0 | 27 | 89 | 80 | 196 | 0 | 12 | 234 | 6 | 252 | 0 | 53 | 48 | 1 | 102 | 0 | 73 | 332 | 74 | 479 | 1029 |
| 04:30 PM | 0 | 71 | 152 | 110 | 333 | 0 | 16 | 197 | 7 | 220 | 0 | 71 | 41 | 0 | 112 | 0 | 65 | 310 | 74 | 449 | 1114 |
| 04:45 PM | 0 | 28 | 80 | 57 | 165 | 0 | 30 | 265 | 10 | 305 | 0 | 59 | 41 | 9 | 109 | 0 | 51 | 371 | 68 | 490 | 1069 |
| 05:00 PM | 0 | 28 | 60 | 34 | 122 | 0 | 22 | 241 | 8 | 271 | 0 | 63 | 34 | 7 | 104 | 0 | 93 | 390 | 92 | 575 | 1072 |
| Total Volume | 0 | 154 | 381 | 281 | 816 | 0 | 80 | 937 | 31 | 1048 | 0 | 246 | 164 | 17 | 427 | 0 | 282 | 1403 | 308 | 1993 | 4284 |
| % App. Total | 0 | 18.9 | 46.7 | 34.4 | | 0 | 7.6 | 89.4 | 3 | | 0 | 57.6 | 38.4 | 4 | | 0 | 14.1 | 70.4 | 15.5 | | |
| PHF | .000 | .542 | .627 | .639 | .613 | .000 | .667 | .884 | .775 | .859 | .000 | .866 | .854 | .472 | .953 | .000 | .758 | .899 | .837 | .867 | .961 |

