

MN Dept of Transportation

TRAFFIC DATA COLLECTION - Metro

TH-36 at English St, NORTH RAMPS
 Ref.Pt.: 007.291
 video MT / RE
 TURN MOVEMENT COUNT

File Name : TH-36 at English St NORTH RAMP 2015
 Site Code :
 Start Date : 12/8/2015
 Page No : 1

Groups Printed- Cars +

Start Time	English St Southbound				ramp from TH-36 WB Westbound				English St Northbound				ramp to TH-36 WB Eastbound				Int. Total
	Left	Thru	Right	Peds	Left	Thru	Right	Peds	Left	Thru	Right	Peds	Left	Thru	Right	Peds	
06:00	0	4	8	0	13	0	5	1	86	17	0	0	0	0	0	0	134
06:15	0	3	11	0	9	1	3	0	92	20	0	0	0	0	0	1	140
06:30	0	8	17	0	7	0	9	0	125	20	0	0	0	0	0	0	186
06:45	0	10	15	0	13	0	17	0	114	25	0	0	0	0	0	0	194
Total	0	25	51	0	42	1	34	1	417	82	0	0	0	0	0	1	654
07:00	0	12	11	0	20	0	9	0	85	23	0	0	0	0	0	2	162
07:15	0	15	15	0	10	0	8	0	91	42	0	0	0	0	0	2	183
07:30	0	13	29	0	21	0	16	0	109	28	0	0	0	0	0	0	216
07:45	0	11	17	0	23	0	16	0	83	27	0	0	0	0	0	0	177
Total	0	51	72	0	74	0	49	0	368	120	0	0	0	0	0	4	738
08:00	0	7	22	0	18	0	15	0	71	31	0	0	0	0	0	1	165
08:15	0	14	24	0	19	0	12	0	63	33	0	0	0	0	0	0	165
08:30	0	15	12	0	8	0	3	0	71	27	0	0	0	0	0	2	138
08:45	0	11	20	0	19	0	5	0	60	20	0	0	0	0	0	0	135
Total	0	47	78	0	64	0	35	0	265	111	0	0	0	0	0	3	603
09:00	0	27	24	0	11	0	6	0	77	27	0	0	0	0	0	2	174
09:15	0	17	13	0	17	0	3	0	79	24	0	0	0	0	0	0	153
09:30	0	15	17	0	10	2	6	0	51	23	0	0	0	0	0	0	124
09:45	0	9	15	0	14	0	4	0	58	28	0	0	0	0	0	0	128
Total	0	68	69	0	52	2	19	0	265	102	0	0	0	0	0	2	579
10:00	0	8	15	0	18	0	4	0	56	25	0	0	0	0	0	0	126
10:15	0	15	20	0	20	0	6	0	38	19	0	0	0	0	0	0	118
10:30	0	13	17	0	22	0	10	1	46	23	0	0	0	0	0	0	132
10:45	0	16	15	0	24	0	5	0	35	21	0	0	0	0	0	0	116
Total	0	52	67	0	84	0	25	1	175	88	0	0	0	0	0	0	492
11:00	0	27	18	0	21	1	5	0	60	21	0	0	0	0	0	2	155
11:15	0	21	12	0	15	1	7	0	61	22	0	0	0	0	0	0	139
11:30	0	38	23	0	20	0	5	0	58	38	0	0	0	0	0	0	182
11:45	0	18	17	0	17	1	9	0	61	35	0	0	0	0	0	0	158
Total	0	104	70	0	73	3	26	0	240	116	0	0	0	0	0	2	634
12:00	0	28	24	0	25	0	10	0	57	33	0	0	0	0	0	0	177
12:15	0	18	18	0	21	2	8	0	56	20	0	0	0	0	0	0	143
12:30	0	27	13	0	17	0	13	0	68	27	0	0	0	0	0	0	165
12:45	0	24	14	0	21	0	7	0	59	26	0	0	0	0	0	0	151
Total	0	97	69	0	84	2	38	0	240	106	0	0	0	0	0	0	636
13:00	0	11	17	0	14	0	4	0	47	32	0	0	0	0	0	0	125
13:15	0	18	15	0	18	1	2	0	67	30	0	0	0	0	0	0	151
13:30	0	8	20	0	17	0	10	0	80	29	0	0	0	0	0	0	164
13:45	0	18	12	0	22	0	8	0	50	33	0	0	0	0	0	0	143
Total	0	55	64	0	71	1	24	0	244	124	0	0	0	0	0	0	583
14:00	0	15	9	0	23	0	3	0	74	24	0	0	0	0	0	0	148
14:15	0	14	26	0	23	0	8	0	69	27	0	0	0	0	0	0	167
14:30	0	20	30	0	25	0	4	0	75	24	0	0	0	0	0	0	178
14:45	0	24	16	0	28	0	2	0	70	25	0	0	0	0	0	0	165
Total	0	73	81	0	99	0	17	0	288	100	0	0	0	0	0	0	658
15:00	0	17	20	0	46	0	5	0	76	17	0	0	0	0	0	0	181
15:15	0	27	16	2	33	0	2	0	78	37	0	0	0	0	0	0	195
15:30	0	30	18	0	29	0	6	0	67	36	0	0	0	0	0	0	186
15:45	0	25	16	0	48	1	4	0	81	34	0	0	0	0	0	0	209
Total	0	99	70	2	156	1	17	0	302	124	0	0	0	0	0	0	771

MN Dept of Transportation

TRAFFIC DATA COLLECTION - Metro

TH-36 at English St, NORTH RAMPS
 Ref.Pt.: 007.291
 video MT / RE
 TURN MOVEMENT COUNT

File Name : TH-36 at English St NORTH RAMP 2015
 Site Code :
 Start Date : 12/8/2015
 Page No : 3

Start Time	English St Southbound					ramp from TH-36 WB Westbound					English St Northbound					ramp to TH-36 WB Eastbound					Int. Total
	Left	Thru	Right	Peds	App. Total	Left	Thru	Right	Peds	App. Total	Left	Thru	Right	Peds	App. Total	Left	Thru	Right	Peds	App. Total	
Peak Hour Analysis From 06:00 to 11:45 - Peak 1 of 1																					
Peak Hour for Entire Intersection Begins at 06:45																					
06:45	0	10	15	0	25	13	0	17	0	30	114	25	0	0	139	0	0	0	0	0	194
07:00	0	12	11	0	23	20	0	9	0	29	85	23	0	0	108	0	0	0	2	2	162
07:15	0	15	15	0	30	10	0	8	0	18	91	42	0	0	133	0	0	0	2	2	183
07:30	0	13	29	0	42	21	0	16	0	37	109	28	0	0	137	0	0	0	0	0	216
Total Volume	0	50	70	0	120	64	0	50	0	114	399	118	0	0	517	0	0	0	4	4	755
% App. Total	0	41.7	58.3	0		56.1	0	43.9	0		77.2	22.8	0	0		0	0	0	100		
PHF	.000	.833	.603	.000	.714	.762	.000	.735	.000	.770	.875	.702	.000	.000	.930	.000	.000	.000	.500	.500	.874

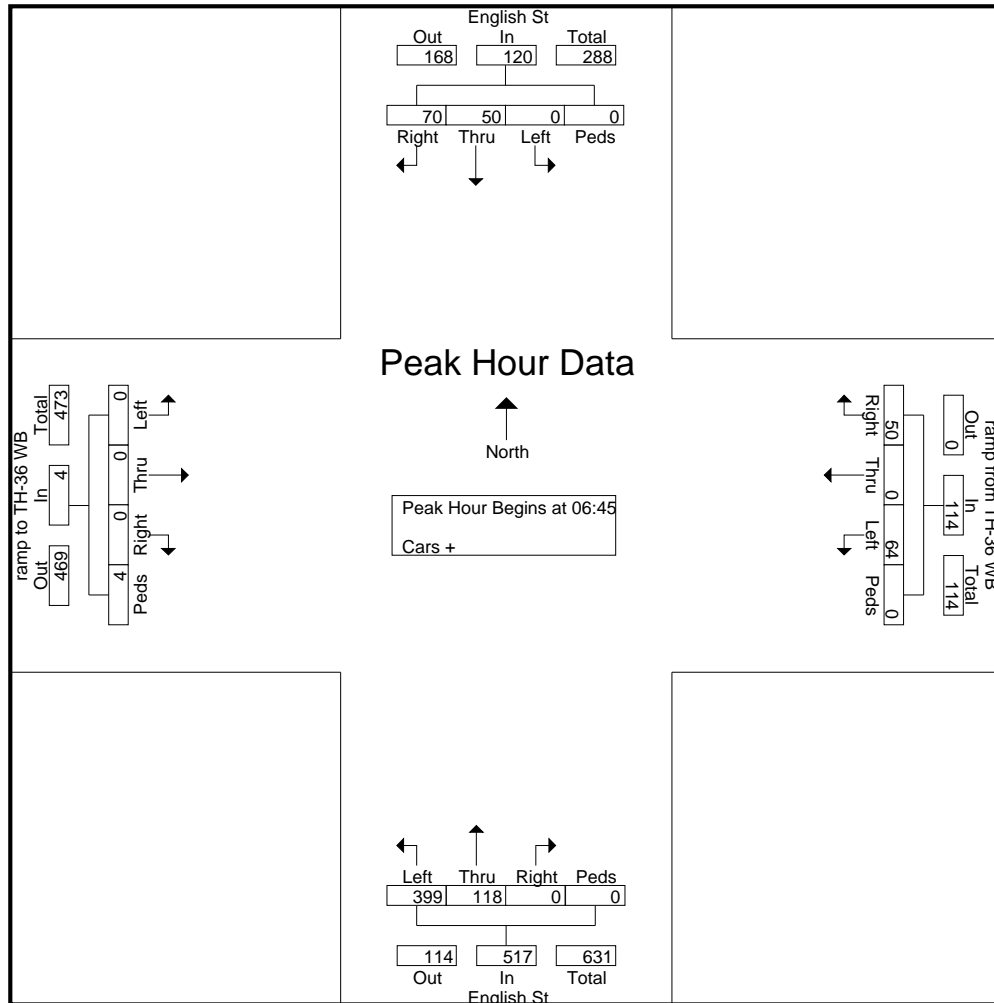

MN Dept of Transportation

TRAFFIC DATA COLLECTION - Metro

TH-36 at English St, NORTH RAMPS
 Ref.Pt.: 007.291
 video MT / RE
 TURN MOVEMENT COUNT

File Name : TH-36 at English St NORTH RAMP 2015
 Site Code :
 Start Date : 12/8/2015
 Page No : 4

Start Time	English St Southbound					ramp from TH-36 WB Westbound					English St Northbound					ramp to TH-36 WB Eastbound					Int. Total
	Left	Thru	Right	Peds	App. Total	Left	Thru	Right	Peds	App. Total	Left	Thru	Right	Peds	App. Total	Left	Thru	Right	Peds	App. Total	
Peak Hour Analysis From 12:00 to 17:45 - Peak 1 of 1																					
Peak Hour for Entire Intersection Begins at 15:45																					
15:45	0	25	16	0	41	48	1	4	0	53	81	34	0	0	115	0	0	0	0	0	209
16:00	0	50	38	0	88	20	0	3	0	23	95	29	0	0	124	0	0	0	0	0	235
16:15	0	19	25	0	44	30	0	4	0	34	96	33	0	0	129	0	0	0	0	0	207
16:30	0	28	31	0	59	23	1	2	0	26	90	25	0	0	115	0	0	0	0	0	200
Total Volume	0	122	110	0	232	121	2	13	0	136	362	121	0	0	483	0	0	0	0	0	851
% App. Total	0	52.6	47.4	0		89	1.5	9.6	0		74.9	25.1	0	0		0	0	0	0	0	
PHF	.000	.610	.724	.000	.659	.630	.500	.813	.000	.642	.943	.890	.000	.000	.936	.000	.000	.000	.000	.000	.905

