

TH 3 at Hester St  
 Carto Measure: 10.276  
 Data By: Short Elliott Hendrickson, Inc.  
 TURN MOVEMENT COUNT

File Name : TH 3 & Hester St 2019  
 Site Code : 1a  
 Start Date : 10/9/2019  
 Page No : 1

Groups Printed- Vehicles - Trucks

Start Time	TH 3 Southbound					Hester St Westbound					TH 3 Northbound					Hester St Eastbound					Int. Total
	Right	Thru	Left	Peds	App. Total	Right	Thru	Left	Peds	App. Total	Right	Thru	Left	Peds	App. Total	Right	Thru	Left	Peds	App. Total	
06:00 AM	3	21	0	0	24	0	0	0	0	0	2	53	0	0	55	1	1	6	0	8	87
06:15 AM	12	39	1	0	52	0	0	2	0	2	1	75	9	0	85	6	0	3	0	9	148
06:30 AM	20	58	0	0	78	0	0	0	0	0	0	95	6	0	101	5	0	8	0	13	192
06:45 AM	5	54	0	0	59	0	0	2	0	2	1	92	5	0	98	7	0	14	0	21	180
Total	40	172	1	0	213	0	0	4	0	4	4	315	20	0	339	19	1	31	0	51	607
07:00 AM	16	84	0	0	100	0	0	1	0	1	0	75	4	0	79	6	2	6	0	14	194
07:15 AM	15	79	0	0	94	0	1	0	0	1	2	92	5	0	99	6	1	21	0	28	222
07:30 AM	17	91	2	0	110	1	2	1	0	4	1	113	6	0	120	7	3	5	0	15	249
07:45 AM	11	63	2	0	76	0	1	1	0	2	1	114	5	0	120	1	1	27	0	29	227
Total	59	317	4	0	380	1	4	3	0	8	4	394	20	0	418	20	7	59	0	86	892
08:00 AM	20	64	0	0	84	0	0	0	0	0	2	89	3	0	94	4	0	17	0	21	199
08:15 AM	35	45	0	0	80	0	2	1	0	3	5	130	8	0	143	7	0	15	0	22	248
08:30 AM	28	64	1	0	93	0	0	2	0	2	0	109	8	0	117	6	1	21	0	28	240
08:45 AM	30	52	1	0	83	0	0	2	0	2	2	99	13	1	115	4	3	30	0	37	237
Total	113	225	2	0	340	0	2	5	0	7	9	427	32	1	469	21	4	83	0	108	924
09:00 AM	21	72	2	0	95	0	3	3	0	6	0	79	6	0	85	9	0	23	0	32	218
09:15 AM	27	50	1	0	78	2	2	3	0	7	6	60	8	0	74	10	2	24	0	36	195
09:30 AM	17	68	0	0	85	1	1	0	0	2	1	75	11	0	87	10	4	27	0	41	215
09:45 AM	34	53	1	0	88	0	5	1	0	6	0	76	11	0	87	10	3	24	0	37	218
Total	99	243	4	0	346	3	11	7	0	21	7	290	36	0	333	39	9	98	0	146	846
10:00 AM	31	67	1	0	99	0	5	0	0	5	3	59	12	0	74	14	2	48	0	64	242
10:15 AM	33	71	0	0	104	0	3	0	0	3	1	54	12	0	67	7	0	33	0	40	214
10:30 AM	25	72	2	0	99	1	1	2	0	4	0	60	7	0	67	19	5	35	0	59	229
10:45 AM	32	76	1	0	109	1	6	1	0	8	2	70	9	0	81	4	2	32	0	38	236
Total	121	286	4	0	411	2	15	3	0	20	6	243	40	0	289	44	9	148	0	201	921
11:00 AM	23	70	1	0	94	0	1	3	0	4	2	83	9	0	94	9	2	32	0	43	235
11:15 AM	33	69	1	0	103	2	3	0	0	5	1	64	13	0	78	16	7	32	0	55	241
11:30 AM	32	65	1	0	98	2	3	2	0	7	3	66	9	0	78	14	2	40	0	56	239
11:45 AM	36	62	1	0	99	0	2	1	0	3	0	66	15	0	81	12	3	35	0	50	233
Total	124	266	4	0	394	4	9	6	0	19	6	279	46	0	331	51	14	139	0	204	948
12:00 PM	35	75	0	0	110	0	4	2	0	6	1	47	11	0	59	8	3	34	0	45	220
12:15 PM	34	69	1	0	104	2	1	4	0	7	5	78	8	0	91	13	2	29	0	44	246
12:30 PM	25	74	0	0	99	1	3	3	0	7	2	66	7	0	75	12	2	42	0	56	237
12:45 PM	20	74	2	0	96	0	4	0	0	4	2	64	16	0	82	13	6	26	0	45	227
Total	114	292	3	0	409	3	12	9	0	24	10	255	42	0	307	46	13	131	0	190	930
01:00 PM	45	70	2	0	117	0	5	3	0	8	4	69	8	0	81	8	3	35	0	46	252
01:15 PM	32	68	0	1	101	0	5	2	0	7	3	59	16	0	78	18	3	45	0	66	252
01:30 PM	38	65	0	0	103	1	1	2	0	4	6	71	9	0	86	12	1	36	0	49	242
01:45 PM	36	62	0	0	98	0	2	3	0	5	2	77	4	0	83	15	2	35	0	52	238
Total	151	265	2	1	419	1	13	10	0	24	15	276	37	0	328	53	9	151	0	213	984
02:00 PM	20	95	0	0	115	1	4	2	0	7	3	62	4	0	69	20	3	34	0	57	248
02:15 PM	20	92	0	0	112	0	0	2	0	2	1	77	9	0	87	18	7	29	0	54	255
02:30 PM	21	94	0	0	115	0	8	4	0	12	4	104	10	0	118	20	1	28	0	49	294
02:45 PM	32	97	4	0	133	0	4	5	0	9	3	76	10	0	89	16	4	25	0	45	276
Total	93	378	4	0	475	1	16	13	0	30	11	319	33	0	363	74	15	116	0	205	1073
03:00 PM	31	88	1	0	120	1	8	1	0	10	4	73	9	0	86	20	2	41	0	63	279
03:15 PM	38	115	1	0	154	2	3	5	0	10	3	109	7	0	119	23	2	35	0	60	343
03:30 PM	33	124	4	0	161	1	1	4	0	6	2	85	9	0	96	16	6	30	0	52	315

TH 3 at Hester St  
 Carto Measure: 10.276  
 Data By: Short Elliott Hendrickson, Inc.  
 TURN MOVEMENT COUNT

File Name : TH 3 & Hester St 2019  
 Site Code : 1a  
 Start Date : 10/9/2019  
 Page No : 2

Groups Printed- Vehicles - Trucks

Start Time	TH 3 Southbound					Hester St Westbound					TH 3 Northbound					Hester St Eastbound					Int. Total
	Right	Thru	Left	Peds	App. Total	Right	Thru	Left	Peds	App. Total	Right	Thru	Left	Peds	App. Total	Right	Thru	Left	Peds	App. Total	
03:45 PM	34	112	2	0	148	1	8	4	0	13	3	105	9	0	117	28	4	30	0	62	340
Total	136	439	8	0	583	5	20	14	0	39	12	372	34	0	418	87	14	136	0	237	1277
04:00 PM	27	102	0	0	129	1	4	7	0	12	2	84	17	0	103	26	3	56	0	85	329
04:15 PM	26	111	2	0	139	2	8	2	0	12	3	110	13	1	127	20	2	45	0	67	345
04:30 PM	27	128	0	0	155	0	6	4	0	10	1	103	12	0	116	29	6	36	0	71	352
04:45 PM	33	117	3	0	153	0	6	5	0	11	2	134	17	0	153	16	4	47	0	67	384
Total	113	458	5	0	576	3	24	18	0	45	8	431	59	1	499	91	15	184	0	290	1410
05:00 PM	37	119	1	0	157	1	3	6	0	10	2	112	17	0	131	21	4	47	0	72	370
05:15 PM	43	132	0	1	176	0	5	8	0	13	4	115	17	0	136	13	4	33	0	50	375
05:30 PM	24	112	2	0	138	0	8	7	0	15	1	69	11	0	81	18	2	36	0	56	290
05:45 PM	27	82	0	0	109	0	4	7	0	11	3	78	13	0	94	17	5	36	0	58	272
Total	131	445	3	1	580	1	20	28	0	49	10	374	58	0	442	69	15	152	0	236	1307
06:00 PM	35	93	2	0	130	0	0	0	0	0	0	54	9	0	63	11	2	32	0	45	238
06:15 PM	37	76	0	0	113	1	5	2	0	8	4	78	9	0	91	13	2	27	0	42	254
06:30 PM	34	68	1	0	103	0	2	0	0	2	0	68	7	0	75	18	4	42	0	64	244
06:45 PM	25	71	0	0	96	0	0	1	0	1	1	59	6	0	66	9	3	37	0	49	212
Total	131	308	3	0	442	1	7	3	0	11	5	259	31	0	295	51	11	138	0	200	948
Grand Total	1425	4094	47	2	5568	25	153	123	0	301	107	4234	488	2	4831	665	136	1566	0	2367	13067
Apprch %	25.6	73.5	0.8	0		8.3	50.8	40.9	0		2.2	87.6	10.1	0		28.1	5.7	66.2	0		
Total %	10.9	31.3	0.4	0	42.6	0.2	1.2	0.9	0	2.3	0.8	32.4	3.7	0	37	5.1	1	12	0	18.1	
Vehicles	1378	3679										3798						1515			12067
% Vehicles	96.7	89.9	97.9	50	91.7	96	98.7	95.1	0	97	83.2	89.7	99.4	100	90.5	98	95.6	96.7	0	97	92.3
Trucks	47	415	1	1	464	1	2	6	0	9	18	436	3	0	457	13	6	51	0	70	1000
% Trucks	3.3	10.1	2.1	50	8.3	4	1.3	4.9	0	3	16.8	10.3	0.6	0	9.5	2	4.4	3.3	0	3	7.7

TH 3 at Hester St  
 Carto Measure: 10.276  
 Data By: Short Elliott Hendrickson, Inc.  
 TURN MOVEMENT COUNT

File Name : TH 3 & Hester St 2019  
 Site Code : 1a  
 Start Date : 10/9/2019  
 Page No : 3

Start Time	TH 3 Southbound					Hester St Westbound					TH 3 Northbound					Hester St Eastbound					Int. Total
	Right	Thru	Left	Peds	App. Total	Right	Thru	Left	Peds	App. Total	Right	Thru	Left	Peds	App. Total	Right	Thru	Left	Peds	App. Total	
Peak Hour Analysis From 06:00 AM to 08:45 AM - Peak 1 of 1																					
Peak Hour for Entire Intersection Begins at 08:00 AM																					
08:00 AM	20	64	0	0	84	0	0	0	0	0	2	89	3	0	94	4	0	17	0	21	199
08:15 AM	35	45	0	0	80	0	2	1	0	3	5	130	8	0	143	7	0	15	0	22	248
08:30 AM	28	64	1	0	93	0	0	2	0	2	0	109	8	0	117	6	1	21	0	28	240
08:45 AM	30	52	1	0	83	0	0	2	0	2	2	99	13	1	115	4	3	30	0	37	237
Total Volume	113	225	2	0	340	0	2	5	0	7	9	427	32	1	469	21	4	83	0	108	924
% App. Total	33.2	66.2	0.6	0		0	28.6	71.4	0		1.9	91	6.8	0.2		19.4	3.7	76.9	0		
PHF	.807	.879	.500	.000	.914	.000	.250	.625	.000	.583	.450	.821	.615	.250	.820	.750	.333	.692	.000	.730	.931

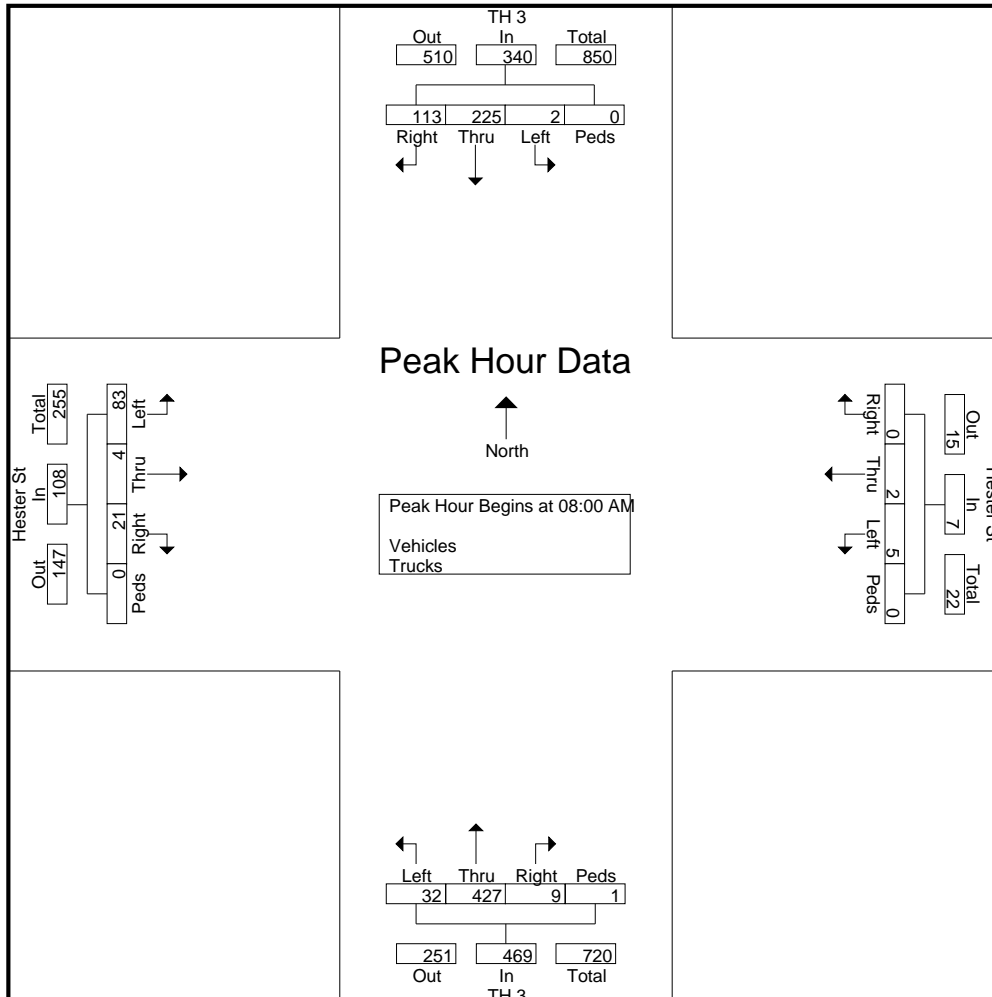

TH 3 at Hester St  
 Carto Measure: 10.276  
 Data By: Short Elliott Hendrickson, Inc.  
 TURN MOVEMENT COUNT

File Name : TH 3 & Hester St 2019  
 Site Code : 1a  
 Start Date : 10/9/2019  
 Page No : 4

Start Time	TH 3 Southbound					Hester St Westbound					TH 3 Northbound					Hester St Eastbound					Int. Total
	Right	Thru	Left	Peds	App. Total	Right	Thru	Left	Peds	App. Total	Right	Thru	Left	Peds	App. Total	Right	Thru	Left	Peds	App. Total	

Peak Hour Analysis From 11:00 AM to 12:45 PM - Peak 1 of 1  
 Peak Hour for Entire Intersection Begins at 11:00 AM

11:00 AM	23	<b>70</b>	1	0	94	0	1	3	0	4	2	<b>83</b>	9	0	<b>94</b>	9	2	32	0	43	235
11:15 AM	33	69	1	0	<b>103</b>	2	3	0	0	5	1	64	13	0	78	<b>16</b>	7	32	0	55	<b>241</b>
11:30 AM	32	65	1	0	98	2	3	2	0	7	3	66	9	0	78	14	2	<b>40</b>	0	<b>56</b>	239
11:45 AM	<b>36</b>	62	1	0	99	0	2	1	0	3	0	66	<b>15</b>	0	81	12	3	35	0	50	233
Total Volume	124	266	4	0	394	4	9	6	0	19	6	279	46	0	331	51	14	139	0	204	948
% App. Total	31.5	67.5	1	0		21.1	47.4	31.6	0		1.8	84.3	13.9	0		25	6.9	68.1	0		
PHF	.861	.950	1.00	.000	.956	.500	.750	.500	.000	.679	.500	.840	.767	.000	.880	.797	.500	.869	.000	.911	.983

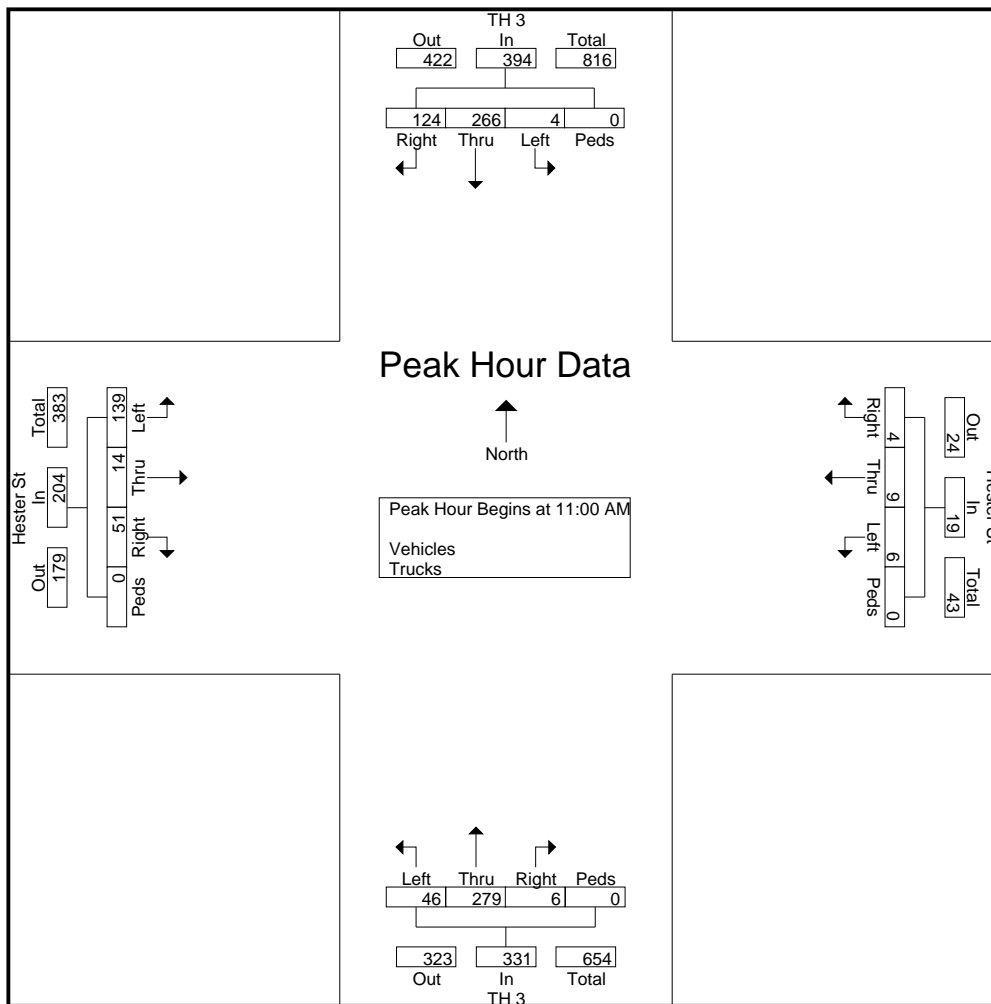

TH 3 at Hester St  
 Carto Measure: 10.276  
 Data By: Short Elliott Hendrickson, Inc.  
 TURN MOVEMENT COUNT

File Name : TH 3 & Hester St 2019  
 Site Code : 1a  
 Start Date : 10/9/2019  
 Page No : 5

Start Time	TH 3 Southbound					Hester St Westbound					TH 3 Northbound					Hester St Eastbound					Int. Total
	Right	Thru	Left	Peds	App. Total	Right	Thru	Left	Peds	App. Total	Right	Thru	Left	Peds	App. Total	Right	Thru	Left	Peds	App. Total	
Peak Hour Analysis From 03:00 PM to 05:45 PM - Peak 1 of 1																					
Peak Hour for Entire Intersection Begins at 04:30 PM																					
04:30 PM	27	128	0	0	155	0	6	4	0	10	1	103	12	0	116	29	6	36	0	71	352
04:45 PM	33	117	3	0	153	0	6	5	0	11	2	134	17	0	153	16	4	47	0	67	384
05:00 PM	37	119	1	0	157	1	3	6	0	10	2	112	17	0	131	21	4	47	0	72	370
05:15 PM	43	132	0	1	176	0	5	8	0	13	4	115	17	0	136	13	4	33	0	50	375
Total Volume	140	496	4	1	641	1	20	23	0	44	9	464	63	0	536	79	18	163	0	260	1481
% App. Total	21.8	77.4	0.6	0.2		2.3	45.5	52.3	0		1.7	86.6	11.8	0		30.4	6.9	62.7	0		
PHF	.814	.939	.333	.250	.911	.250	.833	.719	.000	.846	.563	.866	.926	.000	.876	.681	.750	.867	.000	.903	.964

