



MINNESOTA DEPT OF TRANSPORTATION

TRAFFIC DATA COLLECTION - METRO

TH-282 at Creek Lane JORDAN
 Ref.Pt.: 000.258
 video JI
 TURN MOVEMENT COUNT

File Name : TH-282 at Creek Lane 2013
 Site Code : JORDAN2
 Start Date : 9/10/2013
 Page No : 1

Groups Printed- Cars +

Start Time	Creek Lane Southbound				TH-282 / 2nd St. Westbound				Creek Lane Northbound				TH-282 / 2nd St. Eastbound				Int. Total
	Right	Thru	Left	Peds	Right	Thru	Left	Peds	Right	Thru	Left	Peds	Right	Thru	Left	Peds	
06:00	0	0	2	0	2	38	4	0	0	6	13	0	5	34	1	0	105
06:15	0	0	1	0	2	63	2	0	4	9	19	0	9	38	0	0	147
06:30	0	1	1	0	0	70	5	0	3	10	24	0	12	52	0	0	178
06:45	0	2	0	0	0	94	3	0	6	15	29	0	26	58	1	0	234
Total	0	3	4	0	4	265	14	0	13	40	85	0	52	182	2	0	664
07:00	1	1	0	0	3	63	7	0	4	17	19	0	25	49	1	0	190
07:15	0	1	3	0	3	87	6	0	7	13	25	0	36	50	0	0	231
07:30	1	2	3	0	1	77	24	0	8	16	27	0	30	61	1	0	251
07:45	0	0	2	0	4	84	37	0	13	22	32	0	58	63	1	0	316
Total	2	4	8	0	11	311	74	0	32	68	103	0	149	223	3	0	988
08:00	0	3	4	0	3	84	15	0	22	15	40	0	35	50	1	0	272
08:15	1	1	0	0	2	59	11	0	6	12	24	0	17	52	1	0	186
08:30	1	2	3	0	3	42	4	0	7	7	19	0	16	48	1	0	153
08:45	0	0	2	0	0	36	3	0	3	7	16	0	15	41	4	0	127
Total	2	6	9	0	8	221	33	0	38	41	99	0	83	191	7	0	738
***** BREAK *****																	
15:00	1	2	2	0	3	55	16	0	33	16	53	0	35	73	3	0	292
15:15	2	4	11	0	3	67	10	0	18	8	37	0	17	81	2	0	260
15:30	5	5	7	0	8	60	12	0	11	16	18	0	25	89	3	0	259
15:45	8	9	4	0	5	86	18	0	14	12	26	0	40	89	5	0	316
Total	16	20	24	0	19	268	56	0	76	52	134	0	117	332	13	0	1127
16:00	3	2	2	0	2	80	8	0	17	6	16	0	38	85	2	0	261
16:15	9	3	8	0	9	76	17	0	12	5	26	0	34	92	3	0	294
16:30	2	6	3	0	2	87	13	0	14	6	18	0	43	95	3	0	292
16:45	0	1	2	0	2	86	23	0	15	9	29	0	37	96	1	0	301
Total	14	12	15	0	15	329	61	0	58	26	89	0	152	368	9	0	1148
17:00	3	6	5	0	6	86	20	0	19	6	20	0	47	105	5	0	328
17:15	4	11	3	0	6	93	17	0	16	8	29	0	48	92	3	0	330
17:30	2	5	4	0	4	86	19	0	22	6	16	0	46	94	3	0	307
17:45	5	9	4	0	4	86	18	0	12	7	23	0	41	87	1	0	297
Total	14	31	16	0	20	351	74	0	69	27	88	0	182	378	12	0	1262
Grand Total	48	76	76	0	77	1745	312	0	286	254	598	0	735	1674	46	0	5927
Apprch %	24	38	38	0	3.6	81.8	14.6	0	25.1	22.3	52.5	0	29.9	68.2	1.9	0	
Total %	0.8	1.3	1.3	0	1.3	29.4	5.3	0	4.8	4.3	10.1	0	12.4	28.2	0.8	0	



MINNESOTA DEPT OF TRANSPORTATION

TRAFFIC DATA COLLECTION - METRO

TH-282 at Creek Lane JORDAN
 Ref.Pt.: 000.258
 video JI
 TURN MOVEMENT COUNT

File Name : TH-282 at Creek Lane 2013
 Site Code : JORDAN2
 Start Date : 9/10/2013
 Page No : 2

Start Time	Creek Lane Southbound					TH-282 / 2nd St. Westbound					Creek Lane Northbound					TH-282 / 2nd St. Eastbound					Int. Total
	Right	Thru	Left	Peds	App. Total	Right	Thru	Left	Peds	App. Total	Right	Thru	Left	Peds	App. Total	Right	Thru	Left	Peds	App. Total	
Peak Hour Analysis From 06:00 to 08:45 - Peak 1 of 1																					
Peak Hour for Entire Intersection Begins at 07:15																					
07:15	0	1	3	0	4	3	87	6	0	96	7	13	25	0	45	36	50	0	0	86	231
07:30	1	2	3	0	6	1	77	24	0	102	8	16	27	0	51	30	61	1	0	92	251
07:45	0	0	2	0	2	4	84	37	0	125	13	22	32	0	67	58	63	1	0	122	316
08:00	0	3	4	0	7	3	84	15	0	102	22	15	40	0	77	35	50	1	0	86	272
Total Volume	1	6	12	0	19	11	332	82	0	425	50	66	124	0	240	159	224	3	0	386	1070
% App. Total	5.3	31.6	63.2	0		2.6	78.1	19.3	0		20.8	27.5	51.7	0		41.2	58	0.8	0		
PHF	.250	.500	.750	.000	.679	.688	.954	.554	.000	.850	.568	.750	.775	.000	.779	.685	.889	.750	.000	.791	.847

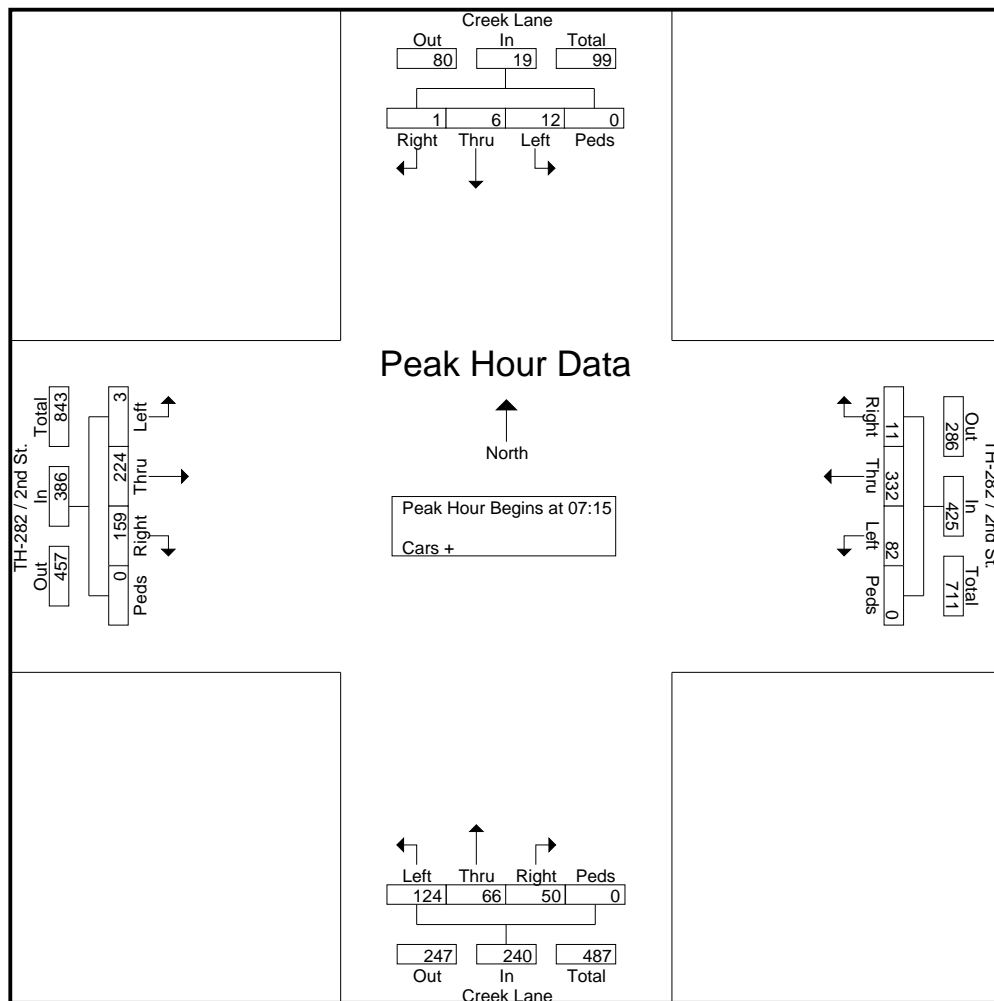



MINNESOTA DEPT OF TRANSPORTATION

TRAFFIC DATA COLLECTION - METRO

TH-282 at Creek Lane JORDAN
 Ref.Pt.: 000.258
 video JI
 TURN MOVEMENT COUNT

File Name : TH-282 at Creek Lane 2013
 Site Code : JORDAN2
 Start Date : 9/10/2013
 Page No : 3

Start Time	Creek Lane Southbound					TH-282 / 2nd St. Westbound					Creek Lane Northbound					TH-282 / 2nd St. Eastbound					Int. Total
	Rig ht	Thr u	Left	Ped s	App. Total	Rig ht	Thr u	Left	Ped s	App. Total	Right	Thr u	Left	Peds	App. Total	Right	Thr u	Left	Peds	App. Total	
16:45	0	1	2	0	3	2	86	23	0	111	15	9	29	0	53	37	96	1	0	134	301
17:00	3	6	5	0	14	6	86	20	0	112	19	6	20	0	45	47	105	5	0	157	328
17:15	4	11	3	0	18	6	93	17	0	116	16	8	29	0	53	48	92	3	0	143	330
17:30	2	5	4	0	11	4	86	19	0	109	22	6	16	0	44	46	94	3	0	143	307
Total Volume	9	23	14	0	46	18	351	79	0	448	72	29	94	0	195	178	387	12	0	577	1266
% App. Total	19.6	50	30.4	0		4	78.3	17.6	0		36.9	14.9	48.2	0		30.8	67.1	2.1	0		
PHF	.563	.523	.700	.000	.639	.750	.944	.859	.000	.966	.818	.806	.810	.000	.920	.927	.921	.600	.000	.919	.959

Peak Hour Analysis From 15:00 to 17:45 - Peak 1 of 1
 Peak Hour for Entire Intersection Begins at 16:45

