

Alliant Engineering Inc Minneapolis, MN 55415

TH-149 at Opperman Drive
Ref.Pt.: 001.534
Alliant Engineering Inc
TURN MOVEMENT COUNT

File Name : 18_TH 149 at Opperman Dr_022410
Site Code : 00000018
Start Date : 2/24/2010
Page No : 1

Groups Printed- Unshifted - Bank 1

Start Time	TH-149 Southbound				Opperman Drive Westbound				TH-149 Northbound				Opperman Drive Eastbound				Int. Total
	Left	Thru	Right	Peds	Left	Thru	Right	Peds	Left	Thru	Right	Peds	Left	Thru	Right	Peds	
06:00	5	28	52	0	3	21	8	0	5	65	2	0	1	0	0	0	190
06:15	11	26	76	0	11	26	14	0	15	78	7	0	0	0	0	0	264
06:30	11	38	101	0	6	30	18	0	14	109	0	0	0	0	0	0	327
06:45	16	42	169	0	6	37	12	0	20	133	4	0	4	0	0	0	443
Total	43	134	398	0	26	114	52	0	54	385	13	0	5	0	0	0	1224
07:00	13	30	157	0	9	39	14	0	23	112	1	1	17	2	0	0	418
07:15	13	35	188	0	15	42	11	0	31	173	2	0	10	1	0	0	521
07:30	12	44	195	0	12	43	15	0	26	200	5	0	19	0	0	0	571
07:45	42	67	232	0	8	49	19	0	31	188	14	0	9	0	0	0	659
Total	80	176	772	0	44	173	59	0	111	673	22	1	55	3	0	0	2169
08:00	27	41	216	0	7	53	21	0	24	166	9	0	14	1	0	0	579
08:15	19	54	207	0	6	39	30	0	22	120	14	0	15	3	0	0	529
08:30	6	32	165	0	15	24	35	1	18	57	2	1	5	1	0	0	362
08:45	9	37	166	0	5	11	15	0	18	58	2	0	8	1	1	0	331
Total	61	164	754	0	33	127	101	1	82	401	27	1	42	6	1	0	1801
09:00	6	22	94	0	8	11	12	0	5	38	3	0	7	1	1	0	208
09:15	12	27	71	0	7	9	8	0	2	45	13	0	4	0	2	0	200
*** BREAK ***																	
Total	18	49	165	0	15	20	20	0	7	83	16	0	11	1	3	0	408
*** BREAK ***																	
10:30	9	24	19	0	9	2	16	0	2	43	5	0	15	1	0	0	145
10:45	7	31	18	0	3	2	9	0	4	48	0	0	13	2	1	0	138
Total	16	55	37	0	12	4	25	0	6	91	5	0	28	3	1	0	283
11:00	19	42	16	0	3	1	21	0	1	33	1	0	33	3	0	0	173
11:15	12	29	21	0	2	3	23	0	1	39	1	0	36	6	1	0	174
11:30	16	43	18	0	9	4	15	0	1	48	3	0	40	8	2	0	207
11:45	14	46	29	0	4	4	17	1	1	29	2	0	28	6	4	0	185
Total	61	160	84	0	18	12	76	1	4	149	7	0	137	23	7	0	739
12:00	10	24	21	0	0	6	22	0	1	39	1	0	31	3	2	0	160
12:15	14	39	33	0	1	1	10	0	2	43	7	0	32	5	1	0	188
12:30	16	45	25	0	4	2	13	0	3	35	1	1	36	5	1	0	187
12:45	8	35	30	0	1	4	9	0	5	49	5	0	21	7	1	0	175
Total	48	143	109	0	6	13	54	0	11	166	14	1	120	20	5	0	710
13:00	14	30	46	0	3	4	14	0	4	40	3	0	26	4	1	0	189
13:15	11	33	29	0	1	1	9	1	3	35	1	0	30	3	0	0	157
*** BREAK ***																	
Total	25	63	75	0	4	5	23	1	7	75	4	0	56	7	1	0	346
*** BREAK ***																	
14:30	15	73	33	0	5	0	19	0	1	67	6	0	60	11	2	0	292
14:45	14	57	9	0	4	0	17	0	6	47	5	0	54	13	3	0	229
Total	29	130	42	0	9	0	36	0	7	114	11	0	114	24	5	0	521
15:00	13	59	8	0	7	1	14	0	2	39	1	0	90	24	3	0	261
15:15	13	91	12	0	4	3	18	0	1	35	1	0	80	12	0	0	270
15:30	27	123	12	0	8	1	7	0	0	42	4	0	138	41	3	0	406
15:45	32	100	12	0	3	1	8	0	1	52	5	0	103	23	8	0	348
Total	85	373	44	0	22	6	47	0	4	168	11	0	411	100	14	0	1285

Alliant Engineering Inc Minneapolis, MN 55415

TH-149 at Opperman Drive
Ref.Pt.: 001.534
Alliant Engineering Inc
TURN MOVEMENT COUNT

File Name : 18_TH 149 at Opperman Dr_022410
Site Code : 00000018
Start Date : 2/24/2010
Page No : 2

Groups Printed- Unshifted - Bank 1

Start Time	TH-149 Southbound				Opperman Drive Westbound				TH-149 Northbound				Opperman Drive Eastbound				Int. Total
	Left	Thru	Right	Peds	Left	Thru	Right	Peds	Left	Thru	Right	Peds	Left	Thru	Right	Peds	
16:00	24	113	3	0	6	3	18	0	3	48	7	0	182	38	3	0	448
16:15	27	125	14	0	10	2	20	0	2	52	11	0	196	44	10	0	513
16:30	19	142	12	0	6	2	18	0	2	62	6	0	220	45	11	0	545
16:45	25	120	18	0	14	1	25	0	6	47	7	0	213	43	18	0	537
Total	95	500	47	0	36	8	81	0	13	209	31	0	811	170	42	0	2043
17:00	26	171	22	0	9	0	17	1	3	49	9	0	254	44	12	0	617
17:15	57	147	19	0	12	1	33	0	2	54	17	0	212	48	12	0	614
17:30	69	141	31	0	12	2	56	0	10	65	23	0	224	32	16	0	681
17:45	65	129	11	0	16	2	35	0	2	57	25	0	147	23	6	0	518
Total	217	588	83	0	49	5	141	1	17	225	74	0	837	147	46	0	2430
Grand Total	778	2535	2610	0	274	487	715	4	323	2739	235	3	2627	504	125	0	13959
Apprch %	13.1	42.8	44.1	0	18.5	32.9	48.3	0.3	9.8	83	7.1	0.1	80.7	15.5	3.8	0	
Total %	5.6	18.2	18.7	0	2	3.5	5.1	0	2.3	19.6	1.7	0	18.8	3.6	0.9	0	
Unshifted	773	2484	2576	0	263	482	694	4	316	2648	234	3	2603	500	125	0	13705
% Unshifted	99.4	98	98.7	0	96	99	97.1	100	97.8	96.7	99.6	100	99.1	99.2	100	0	98.2
Bank 1	5	51	34	0	11	5	21	0	7	91	1	0	24	4	0	0	254
% Bank 1	0.6	2	1.3	0	4	1	2.9	0	2.2	3.3	0.4	0	0.9	0.8	0	0	1.8

Alliant Engineering Inc Minneapolis, MN 55415

TH-149 at Opperman Drive
Ref.Pt.: 001.534
Alliant Engineering Inc
TURN MOVEMENT COUNT

File Name : 18_TH 149 at Opperman Dr_022410
Site Code : 00000018
Start Date : 2/24/2010
Page No : 3

Start Time	TH-149 Southbound					Opperman Drive Westbound					TH-149 Northbound					Opperman Drive Eastbound					Int. Total
	Left	Thru	Right	Peds	App. Total	Left	Thru	Right	Peds	App. Total	Left	Thru	Right	Peds	App. Total	Left	Thru	Right	Peds	App. Total	
Peak Hour Analysis From 06:00 to 09:15 - Peak 1 of 1																					
Peak Hour for Entire Intersection Begins at 07:30																					
07:30	12	44	195	0	251	12	43	15	0	70	26	200	5	0	231	19	0	0	0	19	571
07:45	42	67	232	0	341	8	49	19	0	76	31	188	14	0	233	9	0	0	0	9	659
08:00	27	41	216	0	284	7	53	21	0	81	24	166	9	0	199	14	1	0	0	15	579
08:15	19	54	207	0	280	6	39	30	0	75	22	120	14	0	156	15	3	0	0	18	529
Total Volume	100	206	850	0	1156	33	184	85	0	302	103	674	42	0	819	57	4	0	0	61	2338
% App. Total	8.7	17.8	73.5	0		10.9	60.9	28.1	0		12.6	82.3	5.1	0		93.4	6.6	0	0		
PHF	.595	.769	.916	.000	.848	.688	.868	.708	.000	.932	.831	.843	.750	.000	.879	.750	.333	.000	.000	.803	.887

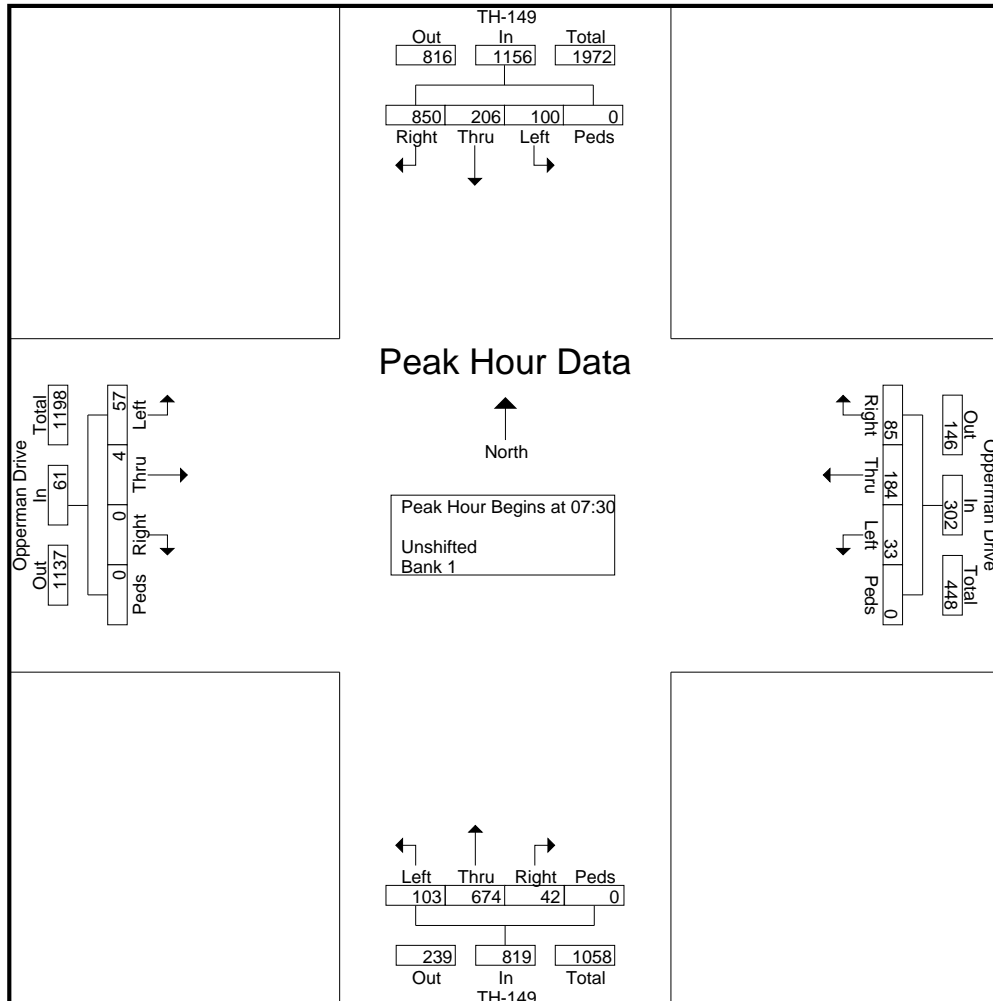

Alliant Engineering Inc Minneapolis, MN 55415

TH-149 at Opperman Drive
Ref.Pt.: 001.534
Alliant Engineering Inc
TURN MOVEMENT COUNT

File Name : 18_TH 149 at Opperman Dr_022410
Site Code : 00000018
Start Date : 2/24/2010
Page No : 4

Start Time	TH-149 Southbound					Opperman Drive Westbound					TH-149 Northbound					Opperman Drive Eastbound					Int. Total
	Left	Thru	Right	Peds	App. Total	Left	Thru	Right	Peds	App. Total	Left	Thru	Right	Peds	App. Total	Left	Thru	Right	Peds	App. Total	
Peak Hour Analysis From 15:00 to 17:45 - Peak 1 of 1																					
Peak Hour for Entire Intersection Begins at 16:45																					
16:45	25	120	18	0	163	14	1	25	0	40	6	47	7	0	60	213	43	18	0	274	537
17:00	26	171	22	0	219	9	0	17	1	27	3	49	9	0	61	254	44	12	0	310	617
17:15	57	147	19	0	223	12	1	33	0	46	2	54	17	0	73	212	48	12	0	272	614
17:30	69	141	31	0	241	12	2	56	0	70	10	65	23	0	98	224	32	16	0	272	681
Total Volume	177	579	90	0	846	47	4	131	1	183	21	215	56	0	292	903	167	58	0	1128	2449
% App. Total	20.9	68.4	10.6	0		25.7	2.2	71.6	0.5		7.2	73.6	19.2	0		80.1	14.8	5.1	0		
PHF	.641	.846	.726	.000	.878	.839	.500	.585	.250	.654	.525	.827	.609	.000	.745	.889	.870	.806	.000	.910	.899

