



# MINNESOTA DEPT OF TRANSPORTATION

## TRAFFIC DATA COLLECTION - METRO

TH-100 NB RAMPS AT 70 TH ST.  
 Ref.Pt.: 001+00.202  
 JAMAR# 634 DR  
 TURN MOVEMENT COUNT

File Name : th 100 nb at 70th st east ramps 2007 ppf  
 Site Code : 00000000  
 Start Date : 10/10/2007  
 Page No : 1

### Groups Printed- Unshifted

Start Time	RAMP FROM 70TH ST. TO TH-100 NB Southbound				70TH ST Westbound				TH 100 NB RAMPS Northbound				70TH ST Eastbound				Int. Total
	Left	Thru	Right	Peds	Left	Thru	Right	Peds	Left	Thru	Right	Peds	Left	Thru	Right	Peds	
06:00	0	0	0	0	0	14	8	0	11	1	6	0	14	20	0	0	74
06:15	0	0	0	0	0	20	16	0	23	4	7	0	21	32	0	0	123
06:30	0	0	0	0	0	20	25	0	20	1	15	0	79	35	0	0	195
06:45	0	0	0	0	0	30	31	0	37	8	20	0	46	55	0	0	227
Total	0	0	0	0	0	84	80	0	91	14	48	0	160	142	0	0	619
07:00	0	0	0	0	0	41	54	0	24	9	24	0	54	73	0	0	279
07:15	0	0	0	0	0	68	67	0	38	8	25	0	89	78	0	0	373
07:30	0	0	0	0	0	66	90	0	22	11	17	0	108	105	0	0	419
07:45	0	0	0	0	0	99	77	0	28	14	22	0	79	103	3	0	425
Total	0	0	0	0	0	274	288	0	112	42	88	0	330	359	3	0	1496
08:00	0	0	0	0	0	88	72	0	16	6	28	0	83	102	0	0	395
08:15	0	0	0	0	0	77	81	0	36	10	31	0	70	127	0	0	432
08:30	0	0	0	0	0	48	70	0	33	12	35	0	75	116	0	0	389
08:45	0	0	0	0	0	40	63	1	26	6	35	0	99	110	0	0	380
Total	0	0	0	0	0	253	286	1	111	34	129	0	327	455	0	0	1596
*** BREAK ***																	
15:00	0	0	0	0	0	76	64	0	26	16	20	0	119	115	0	0	436
15:15	0	0	0	0	0	93	52	0	20	13	22	0	81	142	0	0	423
15:30	0	0	0	0	0	90	54	0	26	6	33	0	104	122	0	0	435
15:45	0	0	0	0	0	97	49	0	15	10	29	0	98	182	0	0	480
Total	0	0	0	0	0	356	219	0	87	45	104	0	402	561	0	0	1774
16:00	0	0	0	0	0	92	68	0	25	13	29	0	160	138	0	0	525
16:15	0	0	0	0	0	92	65	0	20	21	35	0	126	146	0	0	505
16:30	0	0	0	0	0	79	56	0	18	19	40	0	197	184	0	0	593
16:45	0	0	0	0	0	79	76	0	25	13	37	0	193	187	0	0	610
Total	0	0	0	0	0	342	265	0	88	66	141	0	676	655	0	0	2233
17:00	0	0	0	0	0	101	82	4	23	17	45	0	232	223	0	0	727
17:15	0	0	0	0	0	97	71	0	25	27	49	0	205	227	0	0	701
17:30	0	0	0	0	0	108	64	0	25	19	53	0	202	205	0	0	676
17:45	0	0	0	0	0	71	50	0	28	9	42	0	106	163	0	0	469
Total	0	0	0	0	0	377	267	4	101	72	189	0	745	818	0	0	2573
Grand Total	0	0	0	0	0	1686	1405	5	590	273	699	0	2640	2990	3	0	10291
Apprch %	0	0	0	0	0	54.5	45.4	0.2	37.8	17.5	44.8	0	46.9	53.1	0.1	0	
Total %	0	0	0	0	0	16.4	13.7	0	5.7	2.7	6.8	0	25.7	29.1	0	0	



# MINNESOTA DEPT OF TRANSPORTATION

## TRAFFIC DATA COLLECTION - METRO

TH-100 NB RAMPS AT 70 TH ST.  
 Ref.Pt.: 001+00.202  
 JAMAR# 634 DR  
 TURN MOVEMENT COUNT

File Name : th 100 nb at 70th st east ramps 2007 ppf  
 Site Code : 00000000  
 Start Date : 10/10/2007  
 Page No : 2

Start Time	RAMP FROM 70TH ST. TO TH-100 NB Southbound					70TH ST Westbound					TH 100 NB RAMPS Northbound					70TH ST Eastbound					Int. Total
	Left	Thru	Right	Peds	App. Total	Left	Thru	Right	Peds	App. Total	Left	Thru	Right	Peds	App. Total	Left	Thru	Right	Peds	App. Total	
<b>Peak Hour Analysis From 06:00 to 08:45 - Peak 1 of 1</b>																					
Peak Hour for Entire Intersection Begins at 07:30																					
07:30	0	0	0	0	0	0	66	90	0	156	22	11	17	0	50	108	105	0	0	213	419
07:45	0	0	0	0	0	0	99	77	0	176	28	14	22	0	64	79	103	3	0	185	425
08:00	0	0	0	0	0	0	88	72	0	160	16	6	28	0	50	83	102	0	0	185	395
08:15	0	0	0	0	0	0	77	81	0	158	36	10	31	0	77	70	127	0	0	197	432
Total Volume	0	0	0	0	0	0	330	320	0	650	102	41	98	0	241	340	437	3	0	780	1671
% App. Total																					
PHF	.000	.000	.000	.000	.000	.000	.833	.889	.000	.923	.708	.732	.790	.000	.782	.787	.860	.250	.000	.915	.967

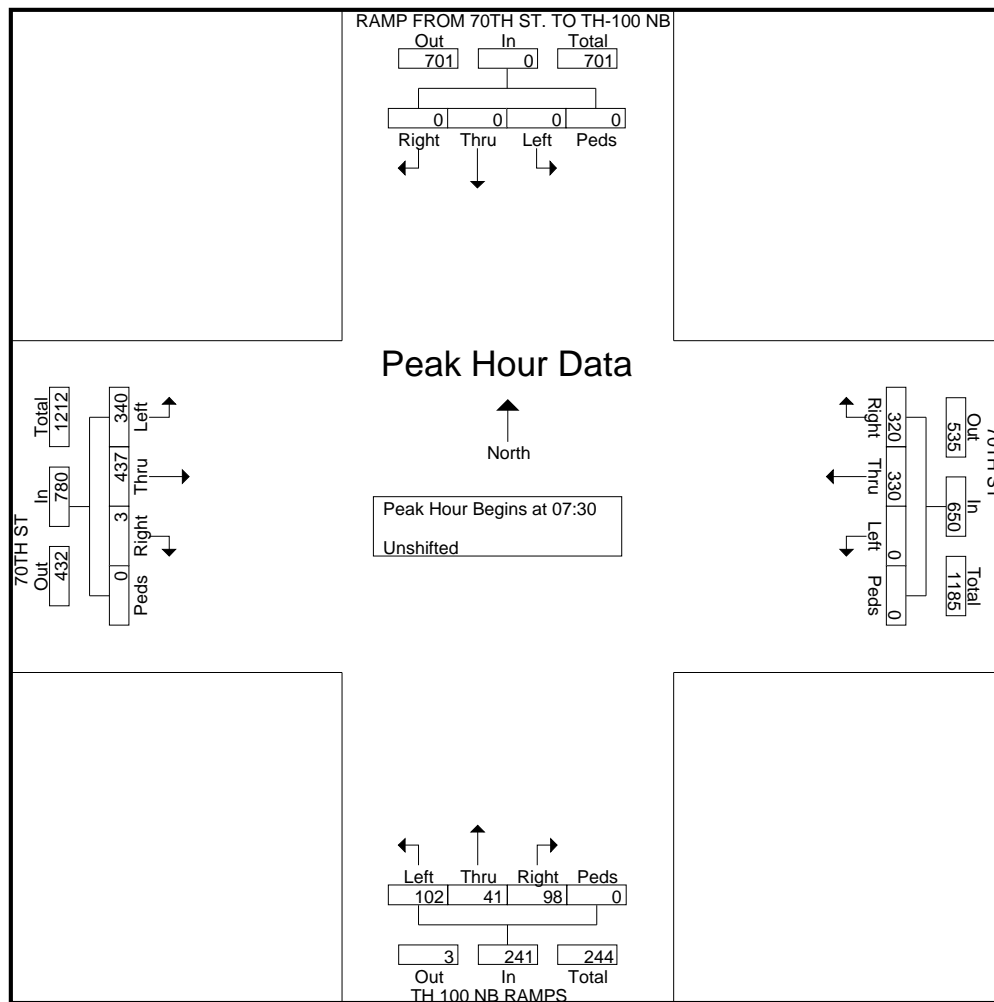



# MINNESOTA DEPT OF TRANSPORTATION

## TRAFFIC DATA COLLECTION - METRO

TH-100 NB RAMPS AT 70 TH ST.  
 Ref.Pt.: 001+00.202  
 JAMAR# 634 DR  
 TURN MOVEMENT COUNT

File Name : th 100 nb at 70th st east ramps 2007 ppf  
 Site Code : 00000000  
 Start Date : 10/10/2007  
 Page No : 3

Start Time	RAMP FROM 70TH ST. TO TH-100 NB Southbound					70TH ST Westbound					TH 100 NB RAMPS Northbound					70TH ST Eastbound					Int. Total
	Left	Thru	Right	Peds	App. Total	Left	Thru	Right	Peds	App. Total	Left	Thru	Right	Peds	App. Total	Left	Thru	Right	Peds	App. Total	
Peak Hour Analysis From 15:00 to 17:45 - Peak 1 of 1																					
Peak Hour for Entire Intersection Begins at 16:45																					
16:45	0	0	0	0	0	0	79	76	0	155	25	13	37	0	75	193	187	0	0	380	610
17:00	0	0	0	0	0	0	101	82	4	187	23	17	45	0	85	232	223	0	0	455	727
17:15	0	0	0	0	0	0	97	71	0	168	25	27	49	0	101	205	227	0	0	432	701
17:30	0	0	0	0	0	0	108	64	0	172	25	19	53	0	97	202	205	0	0	407	676
Total Volume	0	0	0	0	0	0	385	293	4	682	98	76	184	0	358	832	842	0	0	1674	2714
% App. Total																					
PHF	.000	.000	.000	.000	.000	.000	.891	.893	.250	.912	.980	.704	.868	.000	.886	.897	.927	.000	.000	.920	.933

