



MINNESOTA DEPT OF TRANSPORTATION

TRAFFIC DATA COLLECTION - METRO

Loc: I94 NORTH RAMP @ TH120 2006
 REF. PT.: 002+00.154
 JAMAR#D4-3365/BO
 TURN MOVEMENT COUNT

File Name : I94 NORTH RAMP @ TH 120 2006
 Site Code : 00000000
 Start Date : 8/16/2006
 Page No : 1

Groups Printed- CARS & TRUCKS

| Start Time | TH 120 Southbound | | | | I-94 NORTH RAMP Westbound | | | | TH 120 Northbound | | | | N/A Eastbound | | | | Int. Total |
|-------------|-------------------|------|-------|------|---------------------------|------|-------|------|-------------------|------|-------|------|---------------|------|-------|------|------------|
| | Left | Thru | Right | Peds | Left | Thru | Right | Peds | Left | Thru | Right | Peds | Left | Thru | Right | Peds | |
| 06:00 | 0 | 22 | 0 | 0 | 3 | 13 | 42 | 0 | 38 | 32 | 0 | 0 | 0 | 0 | 0 | 0 | 150 |
| 06:15 | 0 | 28 | 0 | 0 | 10 | 15 | 66 | 0 | 64 | 48 | 0 | 0 | 0 | 0 | 0 | 0 | 231 |
| 06:30 | 0 | 51 | 1 | 0 | 9 | 23 | 108 | 0 | 93 | 71 | 1 | 0 | 0 | 0 | 0 | 0 | 357 |
| 06:45 | 0 | 49 | 0 | 0 | 19 | 32 | 136 | 0 | 86 | 115 | 0 | 0 | 0 | 0 | 0 | 0 | 437 |
| Total | 0 | 150 | 1 | 0 | 41 | 83 | 352 | 0 | 281 | 266 | 1 | 0 | 0 | 0 | 0 | 0 | 1175 |
| 07:00 | 0 | 42 | 1 | 0 | 14 | 62 | 120 | 0 | 102 | 106 | 1 | 0 | 0 | 0 | 0 | 0 | 448 |
| 07:15 | 0 | 38 | 0 | 0 | 15 | 64 | 165 | 0 | 81 | 129 | 0 | 2 | 0 | 0 | 0 | 0 | 494 |
| 07:30 | 0 | 63 | 0 | 0 | 24 | 67 | 218 | 0 | 90 | 147 | 0 | 0 | 0 | 0 | 0 | 0 | 609 |
| 07:45 | 0 | 61 | 1 | 0 | 32 | 84 | 240 | 0 | 74 | 162 | 11 | 1 | 0 | 0 | 0 | 0 | 666 |
| Total | 0 | 204 | 2 | 0 | 85 | 277 | 743 | 0 | 347 | 544 | 12 | 3 | 0 | 0 | 0 | 0 | 2217 |
| 08:00 | 0 | 52 | 1 | 0 | 28 | 58 | 187 | 0 | 76 | 158 | 0 | 0 | 0 | 0 | 0 | 0 | 560 |
| 08:15 | 0 | 55 | 1 | 0 | 22 | 36 | 128 | 0 | 60 | 137 | 0 | 0 | 0 | 0 | 0 | 0 | 439 |
| 08:30 | 0 | 52 | 10 | 0 | 16 | 42 | 79 | 0 | 47 | 83 | 0 | 0 | 0 | 0 | 0 | 0 | 329 |
| 08:45 | 0 | 65 | 8 | 0 | 22 | 65 | 90 | 0 | 53 | 130 | 0 | 0 | 0 | 0 | 0 | 0 | 433 |
| Total | 0 | 224 | 20 | 0 | 88 | 201 | 484 | 0 | 236 | 508 | 0 | 0 | 0 | 0 | 0 | 0 | 1761 |
| 15:00 | 0 | 203 | 2 | 0 | 17 | 2 | 10 | 0 | 41 | 161 | 0 | 0 | 0 | 0 | 0 | 0 | 436 |
| 15:15 | 0 | 200 | 3 | 0 | 25 | 3 | 18 | 0 | 37 | 170 | 0 | 0 | 0 | 0 | 0 | 0 | 456 |
| 15:30 | 0 | 212 | 3 | 0 | 27 | 8 | 21 | 1 | 60 | 153 | 0 | 0 | 0 | 0 | 0 | 0 | 485 |
| 15:45 | 0 | 234 | 2 | 0 | 25 | 8 | 22 | 0 | 55 | 164 | 0 | 0 | 0 | 0 | 0 | 0 | 510 |
| Total | 0 | 849 | 10 | 0 | 94 | 21 | 71 | 1 | 193 | 648 | 0 | 0 | 0 | 0 | 0 | 0 | 1887 |
| 16:00 | 0 | 301 | 0 | 0 | 26 | 5 | 17 | 0 | 43 | 196 | 0 | 0 | 0 | 0 | 0 | 0 | 588 |
| 16:15 | 0 | 304 | 2 | 2 | 24 | 6 | 23 | 0 | 42 | 172 | 0 | 0 | 0 | 0 | 0 | 0 | 575 |
| 16:30 | 0 | 361 | 3 | 0 | 16 | 6 | 21 | 0 | 50 | 176 | 1 | 0 | 0 | 0 | 0 | 0 | 634 |
| 16:45 | 0 | 417 | 0 | 0 | 23 | 7 | 28 | 0 | 40 | 170 | 0 | 0 | 0 | 0 | 0 | 0 | 685 |
| Total | 0 | 1383 | 5 | 2 | 89 | 24 | 89 | 0 | 175 | 714 | 1 | 0 | 0 | 0 | 0 | 0 | 2482 |
| 17:00 | 0 | 407 | 0 | 1 | 23 | 5 | 39 | 1 | 30 | 159 | 0 | 0 | 0 | 0 | 0 | 0 | 665 |
| 17:15 | 0 | 399 | 2 | 1 | 34 | 1 | 29 | 0 | 39 | 171 | 0 | 0 | 0 | 0 | 0 | 0 | 676 |
| 17:30 | 0 | 288 | 3 | 0 | 20 | 2 | 22 | 0 | 53 | 127 | 0 | 0 | 0 | 0 | 0 | 0 | 515 |
| 17:45 | 0 | 268 | 2 | 0 | 31 | 3 | 22 | 0 | 34 | 167 | 0 | 0 | 0 | 0 | 0 | 0 | 527 |
| Total | 0 | 1362 | 7 | 2 | 108 | 11 | 112 | 1 | 156 | 624 | 0 | 0 | 0 | 0 | 0 | 0 | 2383 |
| Grand Total | 0 | 4172 | 45 | 4 | 505 | 617 | 1851 | 2 | 1388 | 3304 | 14 | 3 | 0 | 0 | 0 | 0 | 11905 |
| Apprch % | 0 | 98.8 | 1.1 | 0.1 | 17 | 20.7 | 62.2 | 0.1 | 29.5 | 70.2 | 0.3 | 0.1 | 0 | 0 | 0 | 0 | |
| Total % | 0 | 35 | 0.4 | 0 | 4.2 | 5.2 | 15.5 | 0 | 11.7 | 27.8 | 0.1 | 0 | 0 | 0 | 0 | 0 | |



MINNESOTA DEPT OF TRANSPORTATION

TRAFFIC DATA COLLECTION - METRO

File Name : I94 NORTH RAMP @ TH 120 2006

Site Code : 00000000

Start Date : 8/16/2006

Page No : 2

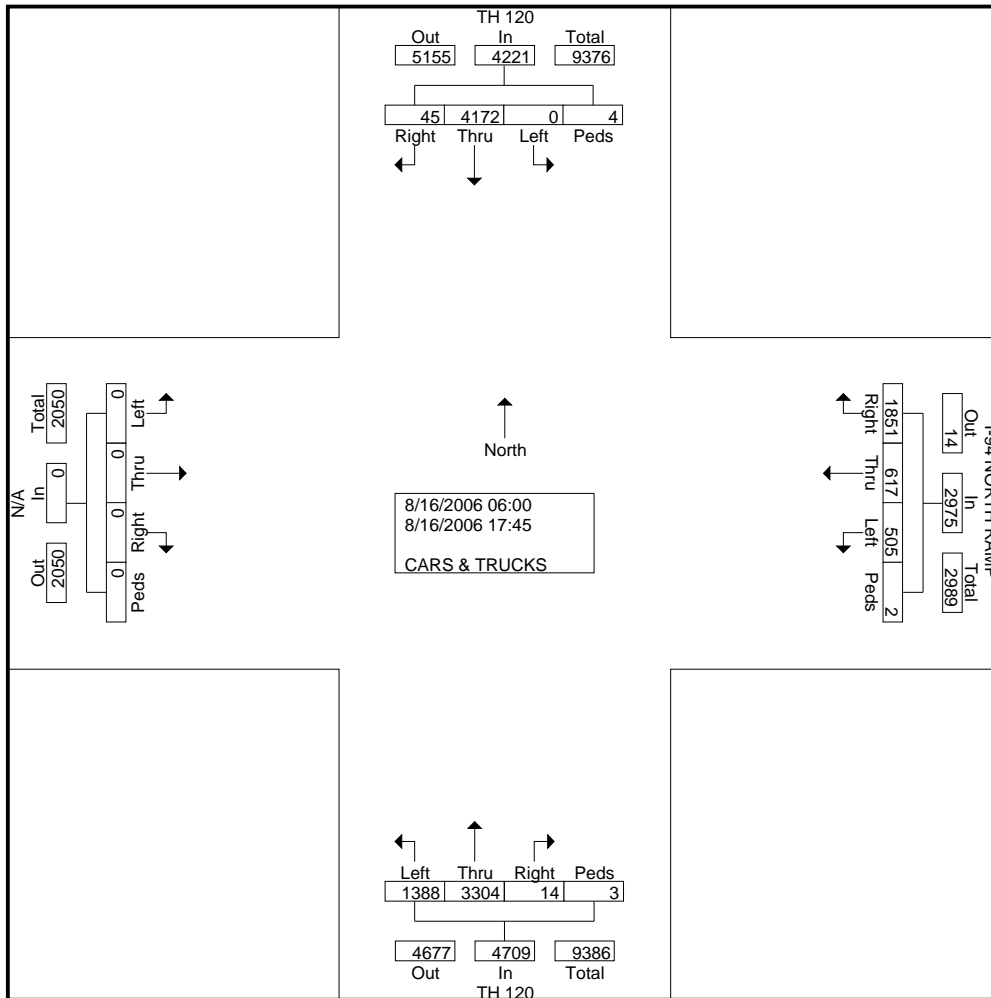



MINNESOTA DEPT OF TRANSPORTATION

TRAFFIC DATA COLLECTION - METRO

File Name : I94 NORTH RAMP @ TH 120 2006

Site Code : 00000000

Start Date : 8/16/2006

Page No : 3

| Start Time | TH 120 Southbound | | | | | I-94 NORTH RAMP Westbound | | | | | TH 120 Northbound | | | | | N/A Eastbound | | | | | Int. Total |
|--|-------------------|------|-------|------|------------|---------------------------|------|-------|------|------------|-------------------|------|-------|------|------------|---------------|------|-------|------|------------|------------|
| | Left | Thru | Right | Peds | App. Total | Left | Thru | Right | Peds | App. Total | Left | Thru | Right | Peds | App. Total | Left | Thru | Right | Peds | App. Total | |
| Peak Hour Analysis From 06:00 to 12:00 - Peak 1 of 1 | | | | | | | | | | | | | | | | | | | | | |
| Peak Hour for Entire Intersection Begins at 07:15 | | | | | | | | | | | | | | | | | | | | | |
| 07:15 | 0 | 38 | 0 | 0 | 38 | 15 | 64 | 165 | 0 | 244 | 81 | 129 | 0 | 2 | 212 | 0 | 0 | 0 | 0 | 0 | 494 |
| 07:30 | 0 | 63 | 0 | 0 | 63 | 24 | 67 | 218 | 0 | 309 | 90 | 147 | 0 | 0 | 237 | 0 | 0 | 0 | 0 | 0 | 609 |
| 07:45 | 0 | 61 | 1 | 0 | 62 | 32 | 84 | 240 | 0 | 356 | 74 | 162 | 11 | 1 | 248 | 0 | 0 | 0 | 0 | 0 | 666 |
| 08:00 | 0 | 52 | 1 | 0 | 53 | 28 | 58 | 187 | 0 | 273 | 76 | 158 | 0 | 0 | 234 | 0 | 0 | 0 | 0 | 0 | 560 |
| Total Volume | 0 | 214 | 2 | 0 | 216 | 99 | 273 | 810 | 0 | 1182 | 321 | 596 | 11 | 3 | 931 | 0 | 0 | 0 | 0 | 0 | 2329 |
| % App. Total | 0 | 99.1 | 0.9 | 0 | | 8.4 | 23.1 | 68.5 | 0 | | 34.5 | 64 | 1.2 | 0.3 | | 0 | 0 | 0 | 0 | | |
| PHF | .000 | .849 | .500 | .000 | .857 | .773 | .813 | .844 | .000 | .830 | .892 | .920 | .250 | .375 | .939 | .000 | .000 | .000 | .000 | .000 | .874 |

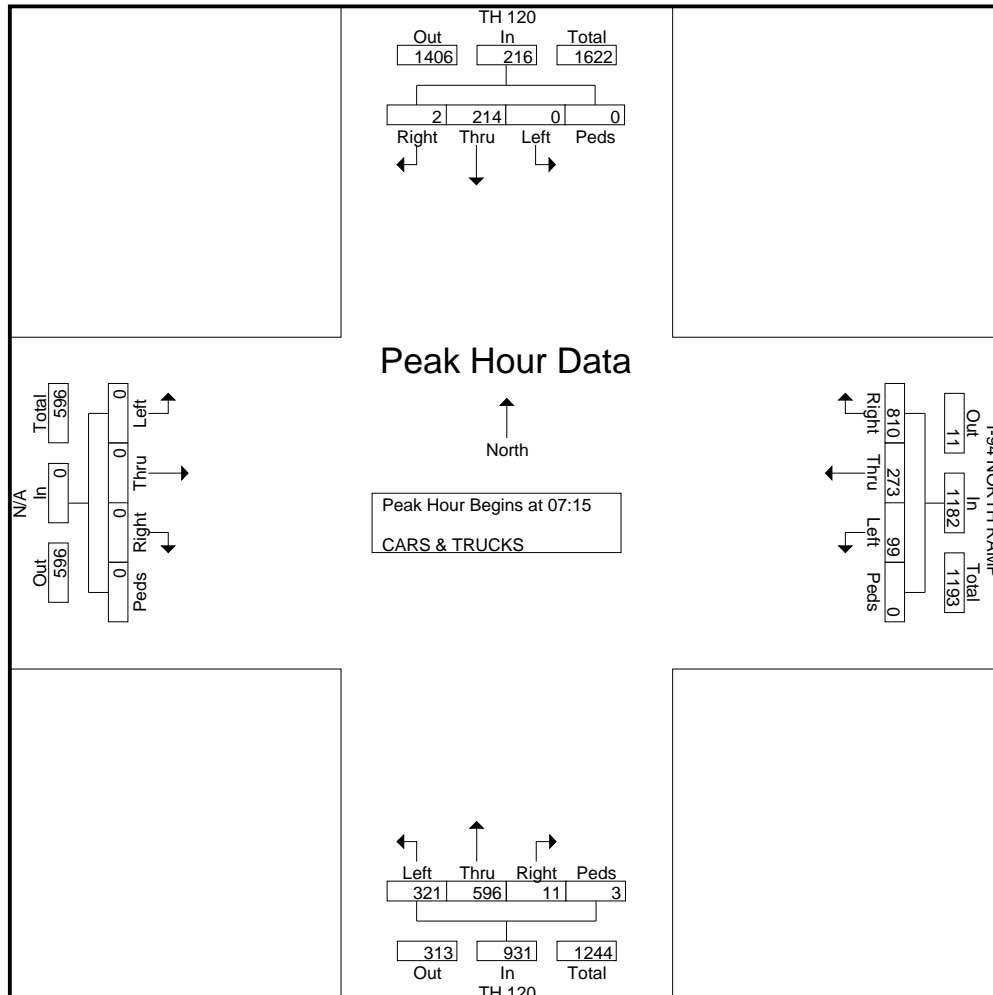



MINNESOTA DEPT OF TRANSPORTATION

TRAFFIC DATA COLLECTION - METRO

File Name : I94 NORTH RAMP @ TH 120 2006

Site Code : 00000000

Start Date : 8/16/2006

Page No : 4

| Start Time | TH 120 Southbound | | | | | I-94 NORTH RAMP Westbound | | | | | TH 120 Northbound | | | | | N/A Eastbound | | | | | Int. Total |
|--|-------------------|------|-------|------|------------|---------------------------|------|-------|------|------------|-------------------|------|-------|------|------------|---------------|------|-------|------|------------|------------|
| | Left | Thru | Right | Peds | App. Total | Left | Thru | Right | Peds | App. Total | Left | Thru | Right | Peds | App. Total | Left | Thru | Right | Peds | App. Total | |
| Peak Hour Analysis From 12:15 to 17:45 - Peak 1 of 1 | | | | | | | | | | | | | | | | | | | | | |
| Peak Hour for Entire Intersection Begins at 16:30 | | | | | | | | | | | | | | | | | | | | | |
| 16:30 | 0 | 361 | 3 | 0 | 364 | 16 | 6 | 21 | 0 | 43 | 50 | 176 | 1 | 0 | 227 | 0 | 0 | 0 | 0 | 0 | 634 |
| 16:45 | 0 | 417 | 0 | 0 | 417 | 23 | 7 | 28 | 0 | 58 | 40 | 170 | 0 | 0 | 210 | 0 | 0 | 0 | 0 | 0 | 685 |
| 17:00 | 0 | 407 | 0 | 1 | 408 | 23 | 5 | 39 | 1 | 68 | 30 | 159 | 0 | 0 | 189 | 0 | 0 | 0 | 0 | 0 | 665 |
| 17:15 | 0 | 399 | 2 | 1 | 402 | 34 | 1 | 29 | 0 | 64 | 39 | 171 | 0 | 0 | 210 | 0 | 0 | 0 | 0 | 0 | 676 |
| Total Volume | 0 | 1584 | 5 | 2 | 1591 | 96 | 19 | 117 | 1 | 233 | 159 | 676 | 1 | 0 | 836 | 0 | 0 | 0 | 0 | 0 | 2660 |
| % App. Total | 0 | 99.6 | 0.3 | 0.1 | | 41.2 | 8.2 | 50.2 | 0.4 | | 19 | 80.9 | 0.1 | 0 | | 0 | 0 | 0 | 0 | | |
| PHF | .000 | .950 | .417 | .500 | .954 | .706 | .679 | .750 | .250 | .857 | .795 | .960 | .250 | .000 | .921 | .000 | .000 | .000 | .000 | .000 | .971 |

