

Associated Consulting Services (ACS)

Saint Paul, MN 55127

-- TRAFFIC DATA --

Stinson Blvd at Broadway St_2019

Ref Pt: 006+00.646

Data Prepared By: ACS

TURNING MOVEMENT COUNT

File Name : Stinson Blvd at Broadway St_2019

Site Code :

Start Date : 7/23/2019

Page No : 1

Groups Printed- Cars - Trucks

Start Time	Stinson Blvd Southbound				Broadway St Westbound				Stinson Blvd Northbound				Broadway St Eastbound				Int. Total
	Left	Thru	Right	Peds	Left	Thru	Right	Peds	Left	Thru	Right	Peds	Left	Thru	Right	Peds	
06:00	25	101	5	1	9	4	8	5	2	14	6	0	5	3	2	0	190
06:15	17	117	1	1	17	2	20	7	1	20	4	1	3	1	1	2	215
06:30	49	150	12	0	12	2	20	7	1	22	4	0	7	2	1	1	290
06:45	59	191	11	0	8	1	25	2	1	22	8	0	5	0	1	3	337
Total	150	559	29	2	46	9	73	21	5	78	22	1	20	6	5	6	1032
07:00	44	134	9	0	9	1	15	6	2	50	9	0	5	3	1	0	288
07:15	84	185	8	1	12	1	24	12	5	47	7	1	1	3	4	4	399
07:30	68	192	16	1	12	2	32	13	6	54	9	1	5	3	4	0	418
07:45	95	230	13	2	16	5	30	8	6	54	26	1	14	2	2	2	506
Total	291	741	46	4	49	9	101	39	19	205	51	3	25	11	11	6	1611
08:00	64	184	14	1	11	8	36	10	5	56	18	0	9	1	8	0	425
08:15	93	175	12	1	19	6	38	16	3	44	13	1	8	1	5	0	435
08:30	63	152	6	0	22	2	24	6	3	52	8	1	6	3	2	0	350
08:45	81	183	22	1	21	5	32	8	4	47	20	1	6	4	10	2	447
Total	301	694	54	3	73	21	130	40	15	199	59	3	29	9	25	2	1657
09:00	48	122	14	0	24	7	57	5	7	54	15	1	10	3	3	0	370
09:15	59	127	13	0	20	13	39	5	7	75	10	1	6	2	3	0	380
09:30	36	81	11	1	13	1	33	8	2	65	12	0	2	8	5	0	278
09:45	43	102	7	2	15	2	29	3	5	59	14	1	8	3	4	0	297
Total	186	432	45	3	72	23	158	21	21	253	51	3	26	16	15	0	1325
10:00	31	61	15	0	17	2	42	4	5	67	11	1	6	3	7	1	273
10:15	36	57	7	0	11	4	38	6	3	68	8	1	7	1	6	1	254
10:30	37	60	15	0	11	6	45	4	5	67	4	1	13	1	8	0	277
10:45	40	74	7	2	10	2	41	6	5	85	8	0	10	3	7	0	300
Total	144	252	44	2	49	14	166	20	18	287	31	3	36	8	28	2	1104
11:00	43	67	9	0	20	5	39	15	2	108	14	0	8	3	5	0	338
11:15	40	86	8	1	15	1	48	4	9	92	18	0	16	2	5	0	345
11:30	40	85	5	0	24	4	54	3	5	134	21	0	11	2	7	0	395
11:45	57	122	14	0	22	3	39	2	5	122	20	0	10	6	8	1	431
Total	180	360	36	1	81	13	180	24	21	456	73	0	45	13	25	1	1509
12:00	46	96	8	0	21	5	77	6	11	156	16	0	27	6	7	0	482
12:15	54	116	19	2	18	5	56	6	5	109	22	0	15	1	6	2	436
12:30	53	134	14	0	19	1	55	9	6	143	15	0	18	2	5	1	475
12:45	54	122	14	1	30	0	63	7	6	102	12	0	8	4	9	1	433
Total	207	468	55	3	88	11	251	28	28	510	65	0	68	13	27	4	1826
13:00	54	113	14	0	16	3	61	2	10	117	13	0	14	4	7	0	428
13:15	46	102	10	0	10	0	43	3	4	93	9	0	12	0	5	0	337
13:30	37	67	13	0	16	1	47	5	1	112	12	1	8	0	6	0	326
13:45	52	71	11	0	17	6	43	2	6	117	13	0	12	3	4	0	357
Total	189	353	48	0	59	10	194	12	21	439	47	1	46	7	22	0	1448
14:00	51	79	14	1	15	1	51	2	4	133	11	0	5	2	5	0	374
14:15	50	62	10	1	18	3	59	3	3	119	14	0	9	1	8	1	361
14:30	51	74	16	0	14	3	54	3	5	143	23	0	7	2	12	0	407

Associated Consulting Services (ACS)

Saint Paul, MN 55127

-- TRAFFIC DATA --

Stinson Blvd at Broadway St_2019

Ref Pt: 006+00.646

Data Prepared By: ACS

TURNING MOVEMENT COUNT

File Name : Stinson Blvd at Broadway St_2019

Site Code :

Start Date : 7/23/2019

Page No : 2

Groups Printed- Cars - Trucks

Start Time	Stinson Blvd Southbound				Broadway St Westbound				Stinson Blvd Northbound				Broadway St Eastbound				Int. Total
	Left	Thru	Right	Peds	Left	Thru	Right	Peds	Left	Thru	Right	Peds	Left	Thru	Right	Peds	
14:45	44	71	9	0	21	5	54	5	4	126	20	0	11	1	3	0	374
Total	196	286	49	2	68	12	218	13	16	521	68	0	32	6	28	1	1516
15:00	45	62	14	0	21	2	79	8	4	204	15	2	11	2	8	0	477
15:15	41	60	8	2	12	3	80	8	3	153	9	3	11	1	8	0	402
15:30	45	53	10	1	12	2	93	8	6	211	15	0	17	2	7	2	484
15:45	48	77	11	1	17	3	84	4	2	181	24	0	11	4	9	1	477
Total	179	252	43	4	62	10	336	28	15	749	63	5	50	9	32	3	1840
16:00	48	69	6	0	20	1	90	3	6	243	25	1	18	4	11	1	546
16:15	60	74	11	2	20	1	90	10	7	229	25	0	28	3	8	3	571
16:30	41	76	11	3	19	8	106	9	5	226	34	3	34	6	9	5	595
16:45	66	72	12	1	15	1	104	25	7	217	33	0	9	3	6	2	573
Total	215	291	40	6	74	11	390	47	25	915	117	4	89	16	34	11	2285
17:00	50	65	11	0	21	5	107	14	5	242	21	2	8	4	9	2	566
17:15	55	71	9	1	22	6	77	7	12	211	28	0	18	3	6	3	529
17:30	44	77	21	0	17	6	74	11	2	173	25	0	15	7	8	0	480
17:45	41	64	7	2	14	4	70	11	5	122	15	1	12	1	9	2	380
Total	190	277	48	3	74	21	328	43	24	748	89	3	53	15	32	7	1955
Grand Total	2428	4965	537	33	795	164	2525	336	228	5360	736	26	519	129	284	43	19108
Apprch %	30.5	62.4	6.7	0.4	20.8	4.3	66.1	8.8	3.6	84.4	11.6	0.4	53.2	13.2	29.1	4.4	
Total %	12.7	26	2.8	0.2	4.2	0.9	13.2	1.8	1.2	28.1	3.9	0.1	2.7	0.7	1.5	0.2	
Cars	2200	4781	493	33	700	138	2318	336	187	5073	646	26	468	102	244	43	17788
% Cars	90.6	96.3	91.8	100	88.1	84.1	91.8	100	82	94.6	87.8	100	90.2	79.1	85.9	100	93.1
Trucks	228	184	44	0	95	26	207	0	41	287	90	0	51	27	40	0	1320
% Trucks	9.4	3.7	8.2	0	11.9	15.9	8.2	0	18	5.4	12.2	0	9.8	20.9	14.1	0	6.9

Associated Consulting Services (ACS)

Saint Paul, MN 55127

-- TRAFFIC DATA --

Stinson Blvd at Broadway St_2019

Ref Pt: 006+00.646

Data Prepared By: ACS

TURNING MOVEMENT COUNT

File Name : Stinson Blvd at Broadway St_2019

Site Code :

Start Date : 7/23/2019

Page No : 3

Start Time	Stinson Blvd Southbound					Broadway St Westbound					Stinson Blvd Northbound					Broadway St Eastbound					Int. Total
	Left	Thru	Right	Peds	App. Total	Left	Thru	Right	Peds	App. Total	Left	Thru	Right	Peds	App. Total	Left	Thru	Right	Peds	App. Total	
Peak Hour Analysis From 06:00 to 11:45 - Peak 1 of 1																					
Peak Hour for Entire Intersection Begins at 07:30																					
07:30	68	192	16	1	277	12	2	32	13	59	6	54	9	1	70	5	3	4	0	12	418
07:45	95	230	13	2	340	16	5	30	8	59	6	54	26	1	87	14	2	2	2	20	506
08:00	64	184	14	1	263	11	8	36	10	65	5	56	18	0	79	9	1	8	0	18	425
08:15	93	175	12	1	281	19	6	38	16	79	3	44	13	1	61	8	1	5	0	14	435
Total Volume	320	781	55	5	1161	58	21	136	47	262	20	208	66	3	297	36	7	19	2	64	1784
% App. Total	27.6	67.3	4.7	0.4		22.1	8	51.9	17.9		6.7	70	22.2	1		56.2	10.9	29.7	3.1		
PHF	.842	.849	.859	.625	.854	.763	.656	.895	.734	.829	.833	.929	.635	.750	.853	.643	.583	.594	.250	.800	.881

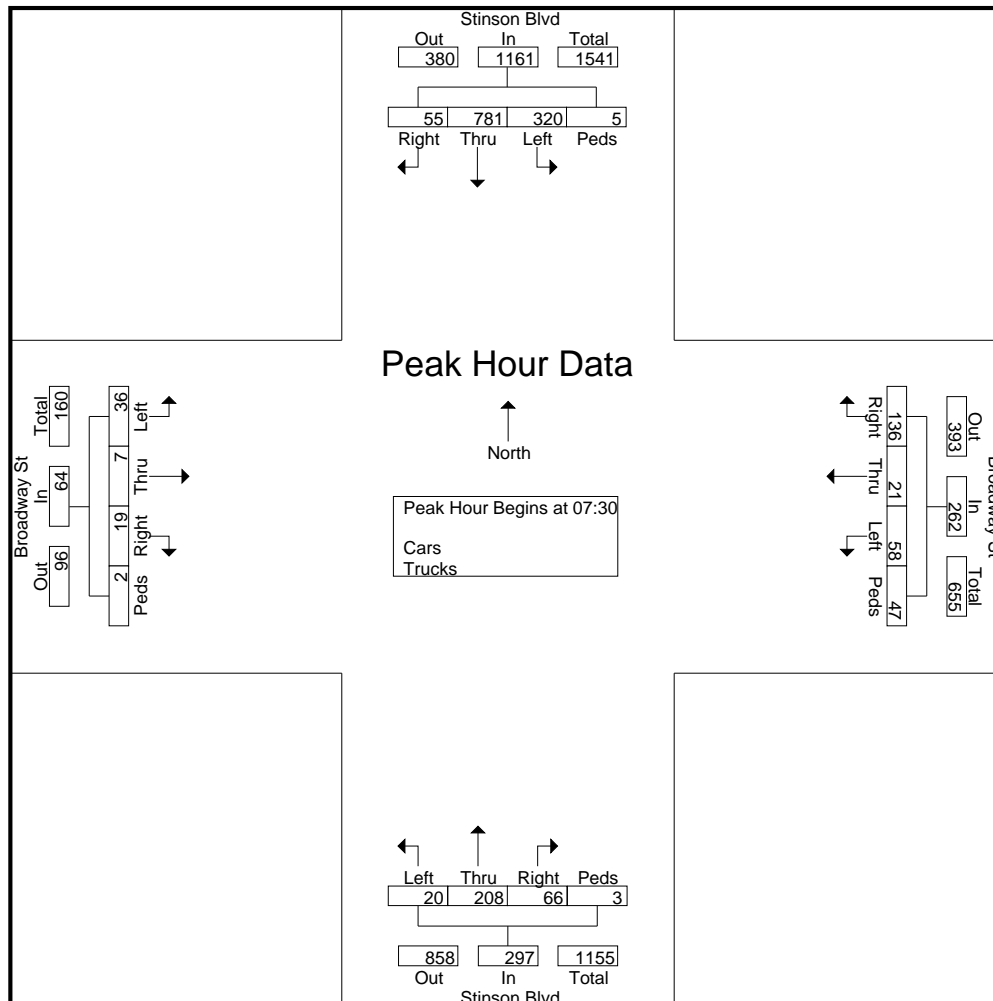

Associated Consulting Services (ACS)

Saint Paul, MN 55127

-- TRAFFIC DATA --

Stinson Blvd at Broadway St_2019

Ref Pt: 006+00.646

Data Prepared By: ACS

TURNING MOVEMENT COUNT

File Name : Stinson Blvd at Broadway St_2019

Site Code :

Start Date : 7/23/2019

Page No : 4

Start Time	Stinson Blvd Southbound					Broadway St Westbound					Stinson Blvd Northbound					Broadway St Eastbound					Int. Total
	Left	Thru	Right	Peds	App. Total	Left	Thru	Right	Peds	App. Total	Left	Thru	Right	Peds	App. Total	Left	Thru	Right	Peds	App. Total	
Peak Hour Analysis From 12:00 to 17:45 - Peak 1 of 1																					
Peak Hour for Entire Intersection Begins at 16:15																					
16:15	60	74	11	2	147	20	1	90	10	121	7	229	25	0	261	28	3	8	3	42	571
16:30	41	76	11	3	131	19	8	106	9	142	5	226	34	3	268	34	6	9	5	54	595
16:45	66	72	12	1	151	15	1	104	25	145	7	217	33	0	257	9	3	6	2	20	573
17:00	50	65	11	0	126	21	5	107	14	147	5	242	21	2	270	8	4	9	2	23	566
Total Volume	217	287	45	6	555	75	15	407	58	555	24	914	113	5	1056	79	16	32	12	139	2305
% App. Total	39.1	51.7	8.1	1.1		13.5	2.7	73.3	10.5		2.3	86.6	10.7	0.5		56.8	11.5	23	8.6		
PHF	.822	.944	.938	.500	.919	.893	.469	.951	.580	.944	.857	.944	.831	.417	.978	.581	.667	.889	.600	.644	.968

