

1217 RESISTANCE OF FINE AGGREGATE TO DEGRADATION BY ABRASION IN THE MICRO-DEVAL APPARATUS

1217.1 SCOPE

This method covers the testing of fine aggregates to determine their abrasion loss in the presence of water and an abrasion charge. It supplies information useful in judging the suitability of a coarse aggregates ability to resist weathering.

1217.2 RELEVANT DOCUMENTS

- A. AASHTO T 27 (Mn/DOT Modified) – Sieve Analysis of Fine and Coarse Aggregates (**Laboratory Manual Section 1202 and 1203**)
- B. AASHTO M 92 – Standard Specifications for Wire-Cloth Sieves for Testing Purposes

1217.3 APPARATUS

- A. MICRO-DEVAL ABRASION MACHINE - A jar rolling mill capable of running at 100 ± 5 rpm (See Section 1217.9)
- B. CONTAINERS – Stainless steel, Micro-Deval abrasion jars having a 5-liter capacity with a rubber ring in the rotary locking cover meeting the following specifications:

Internal diameter = 194.0 ± 2.0 mm
External diameter = 200.0 ± 1.0 mm
Internal height = 175.0 ± 2.0 mm

The inside and outside surfaces of the jars shall be smooth and have no observable ridges or indentations.

- C. ABRASION CHARGE – Stainless steel balls having a diameter of 9.5 ± 0.5 mm.

NOTE 1: Each jar requires a charge of 1250 ± 5 g of balls.

NOTE 2: Prior to use, new containers and new stainless steel balls should be conditioned. Conditioning is accomplished by running the equipment with a charge of 500g of silica sand with 750ml of water for a period of four hours. At the end of the four hours this procedure must be repeated with a new sand sample.

NOTE 3: From time to time it may be necessary to recondition the containers and the stainless steel balls. The need for this will be indicated by a significant change in loss with the control material. It has been found that reconditioning is usually needed when the equipment has been used for testing carbonate, coarse aggregate which leads to polishing the container and stainless steel balls.

- D. Sieves - Standard, 300mm (12") diameter, square opening sieves conforming to the requirements of AASHTO M 92 in the following sizes:

2.36mm (#8)	1.18mm (#16)
600 μ m (#30)	300 μ m (#50)
150 μ m (#100)	75 μ m (#200)

A minimum 200mm (8") diameter, 75 μ m (#200) sieve is to be used for washing the aggregate.

- E. Balance - Conforming to the requirements of AASHTO Designation M 231 (Class G5 or better) with a readability and sensitivity of 1 gram and an accuracy of 1 gram or 0.1%.
- F. Oven - For drying samples capable of maintaining a temperature of 110 ± 5 °C (230 ± 9 °F).
- G. LABORATORY CONTROL AGGREGATE – A supply of standard screenings.

NOTE 4: Available from the Soils & Aggregates Section, Ministry of Transportation, 1201 Wilson Avenue, Downsview, Ontario, Canada M3M 1J8

1217.4 PREPARATION OF TEST SAMPLE

Aggregate for the test shall consist of material passing the 4.75mm (#4) sieve. Split a 725 ± 25 g sample for the Micro-Deval test and place in a sealed container.

1217.5 PROCEDURE

- A. Wash the sample over a 75 μ m (#200) sieve until the wash water is clear.
- B. Oven dry the sample to a constant weight at 110 ± 5 °C (230 ± 9 °F).
- C. The sample shall be sieved into separate sizes. The sample shall be made up to an F.M. of 2.8 using the following weights:

PASSING	RETAINED	WEIGHT (g)
4.75mm (#4)	2.36mm #8)	50
2.36mm (#8)	1.18mm (#16)	125
1.18mm (#16)	600µm (#30)	125
600µm (#30)	300µm (#50)	100
300µm (#50)	150µm (#100)	75
150µm (#100)	75µm (#200)	25
TOTAL		500

Record the total weight to the nearest 0.1g and record. (**A** in the calculation below)

- D. Saturate the sample in tap water for a 24 ± 4 hours.
- E. Pour off the excess and place the sample in the Micro-Deval abrasion container with $1250 \pm 5g$ of the stainless steel balls and $750 \pm 25ml$ of tap water. Place the container on the machine.
- F. Run the machine at 100 ± 5 rpm for 15 minutes ± 10 seconds.
- G. Wash the retained material with water over a 6.7mm (0.265") sieve (to remove stainless steel balls) superimposed over a 75µm (#200) sieve until the washings become clear being careful not to lose any retained 75µm (#200) material.
- H. Oven dry the retained 75µm (#200) material to a constant weight at 110 ± 5 °C (203 ± 9 °F).
- I. Weigh the oven dried sample to the nearest 0.1g. (**B** in the calculation below).

1217.6 CALCULATION

Calculate the Micro-Deval abrasion loss to the nearest 0.1% as follows:

$$\text{Percent Loss} = \frac{A - B}{A} \times 100$$

1217.7 USE OF LABORATORY CONTROL AGGREGATE

- A. Every 10 samples (but, at least once per week in which a sample is tested) a sample of the standard reference aggregate shall also be tested. The material shall be taken from a stock supply, sieved into separate sizes with each size fraction thoroughly washed and dried to a constant weight and then be prepared to the following gradation:

PASSING	RETAINED	WEIGHT (g)
4.75mm (#4)	2.36mm #8)	170
2.36mm (#8)	1.18mm (#16)	115
1.18mm (#16)	600µm (#30)	75
600µm (#30)	300µm (#50)	55
300µm (#50)	150µm (#100)	50
150µm (#100)	75µm (#200)	35
	TOTAL	500

- B. The percent loss of the last twenty samples of the reference material shall be plotted on a control chart in order to monitor the variation in results.

NOTE 5: The mean loss of the control material is 19.9%. Individual test data on this material should not normally be greater than 21.9% nor less than 17.9%.

1217.8 REPORT

The report shall include the following:

- A. The percent loss of the test sample to one decimal place.
- B. The percent loss (to one decimal place) of the reference sample that was tested closest to the time that the aggregate sample was tested.
- C. The percent loss of the last twenty samples of reference material on a control chart.

1217.9 MICRO-DEVAL ABRASION MACHINE AND CONTAINER

Dimensions in millimeters

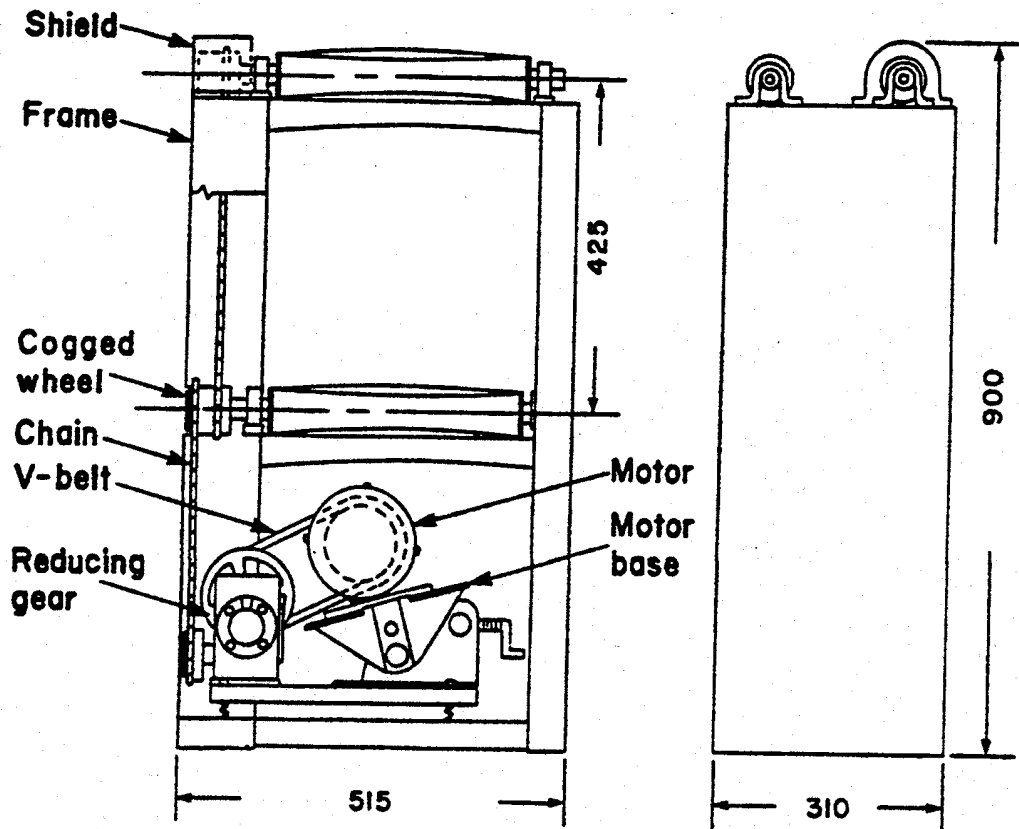
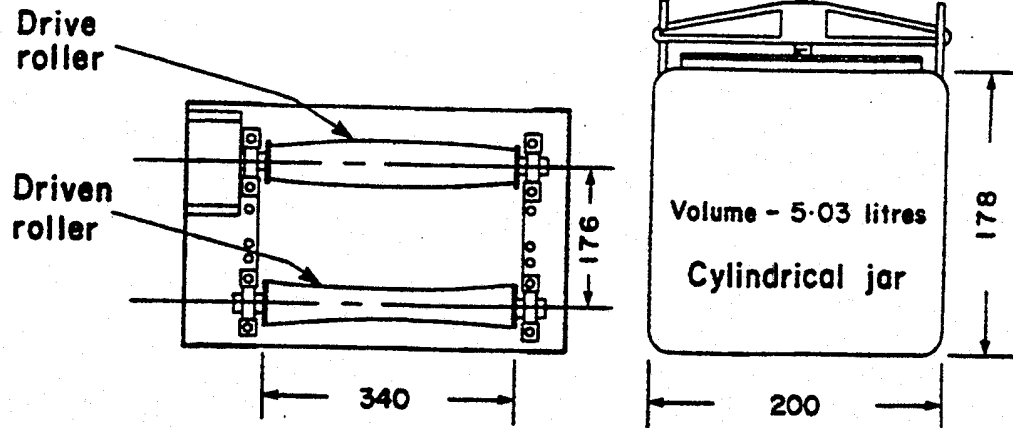

This page intentionally left blank